

EXPERIENCE

Architecture Design Intern ARUP, Toronto	Jan 2024 - Apr 2024
Architecture Designing and Rendering Fiverr.com	July 2022 - Jan 2024
Architecture - Intern Atul Group, Patel's Associate	Apr 2020 - Apr 2021
Civil Engineer - Intern Roohani Infracon	Nov 2019 - Mar 2020

EDUCATION

Architecture Technician Algonquin College, Ottawa, ON, Canada	Jan 2023 - Aug 2024
Bachelor's of Civil Engineering Dharmsinh Desai University, Nadiad, Gujarat, India	Jul 2016 - Apr 2020

SKILLS

BIM, CAD	Revit, AutoCad
Modeling	SketchUp
Rendering	Enscape, D5 Render
Adobe CC	Photoshop, Illustrator, InDesign
Microsoft Office	Word, Powerpoint, Excel

LANGUAGES

English	C1
Hindi	Native
Gujarati	Native

Contents

- 01** Warming Huts
Art + Architecture Competition
- 02** International Airport & Transit (Confidential)
ARUP
- 03** Library
Fiverr.com
- 04** Administration Building
Algonquin College
- 05** Retreat House
Algonquin College
- 06** Province of Ontario and Equipment Repair Facility
Algonquin College
- 07** Lowertown Medical Center
Algonquin College

01 Warming Huts

Year : 2023
Type : Arts + Architecture Competition
Team : Sole
Role : Architecture Designer
Status: Completed

The warming hut is designed for winter visitors to Winnipeg, specifically for those enjoying snow skating on the frozen Assiniboine and Red Rivers. The structure's form reflects the flowing curves of these rivers, creating a seamless connection with the natural environment. During winter, snow depths can reach up to 1 meter thick, and the hut provides essential shelter from the wind and cold. Constructed from lightweight steel or aluminum, with expansive glass panels, the design offers a protective yet open space. Its minimalist approach ensures that the surrounding landscape remains the focal point, offering skaters a cozy refuge to warm up and rest. The use of transparent materials enhances the experience by allowing views of the surrounding icy landscape while remaining shielded from the elements. This project celebrates the winter season, providing both a functional and aesthetic haven for outdoor enthusiasts.

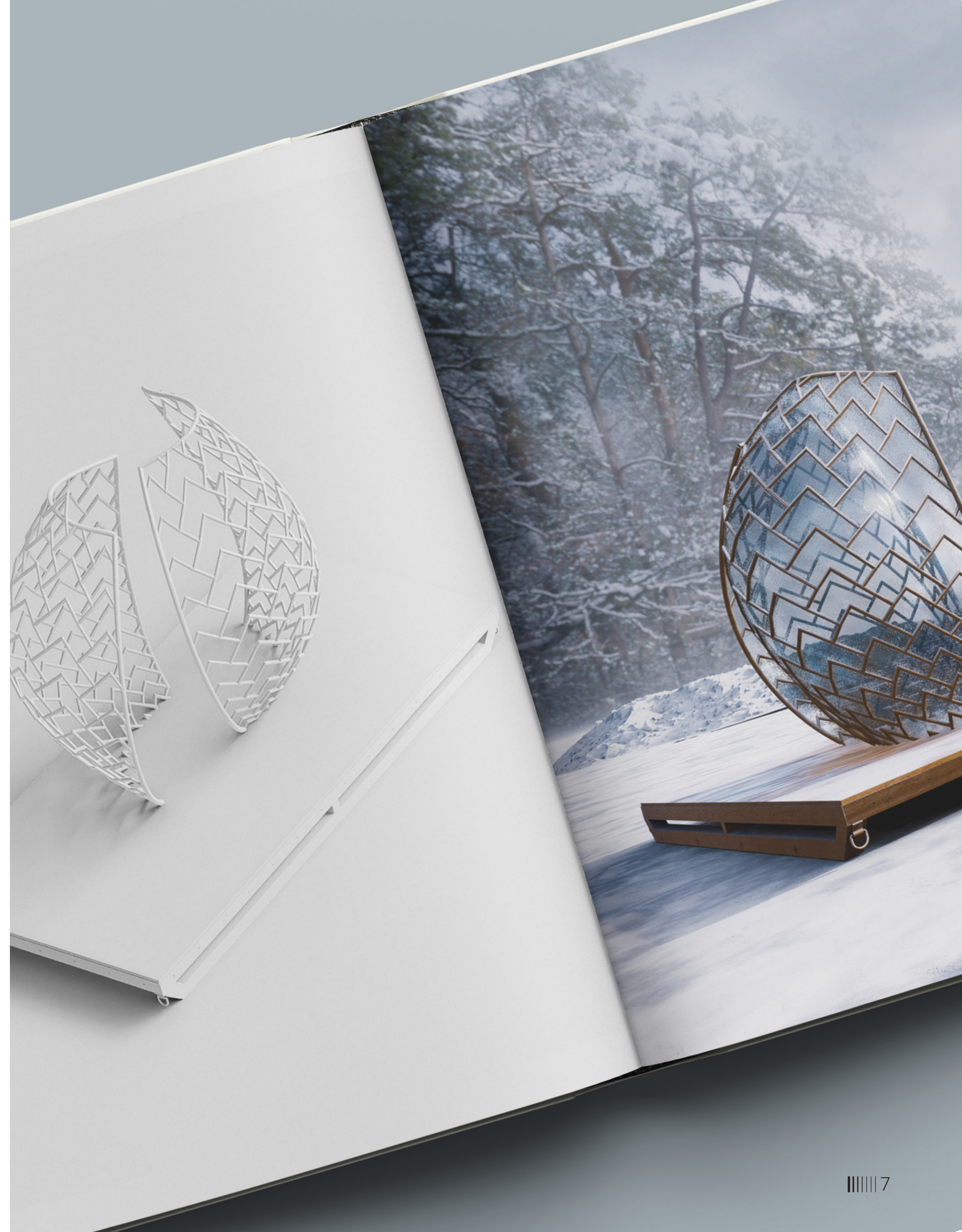

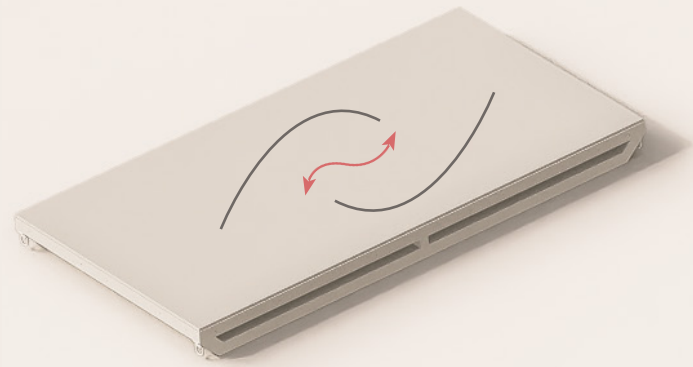

1. Interact

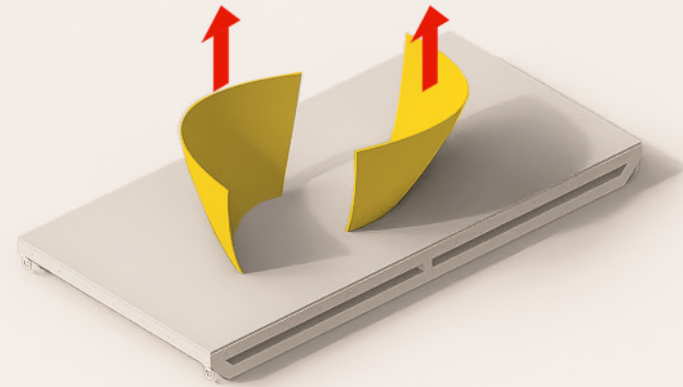

2. Lift

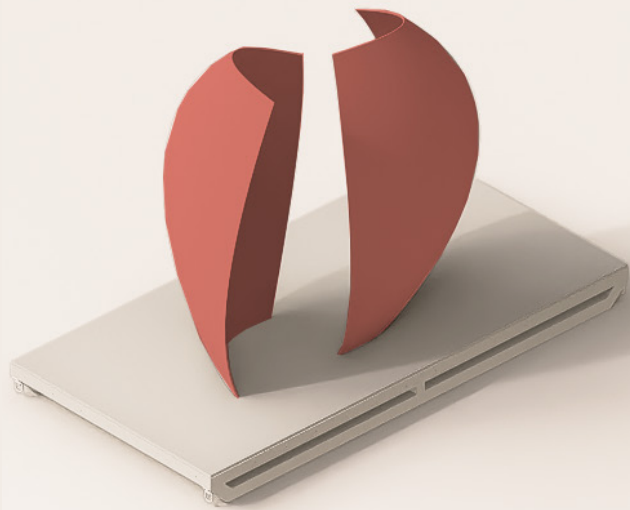

3. Form

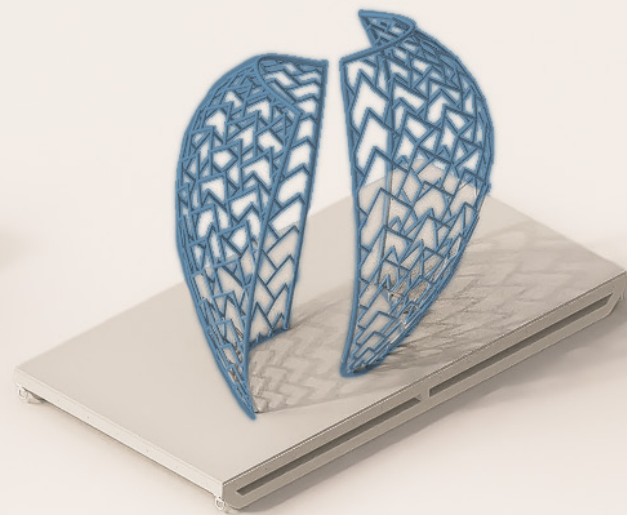

4. Built

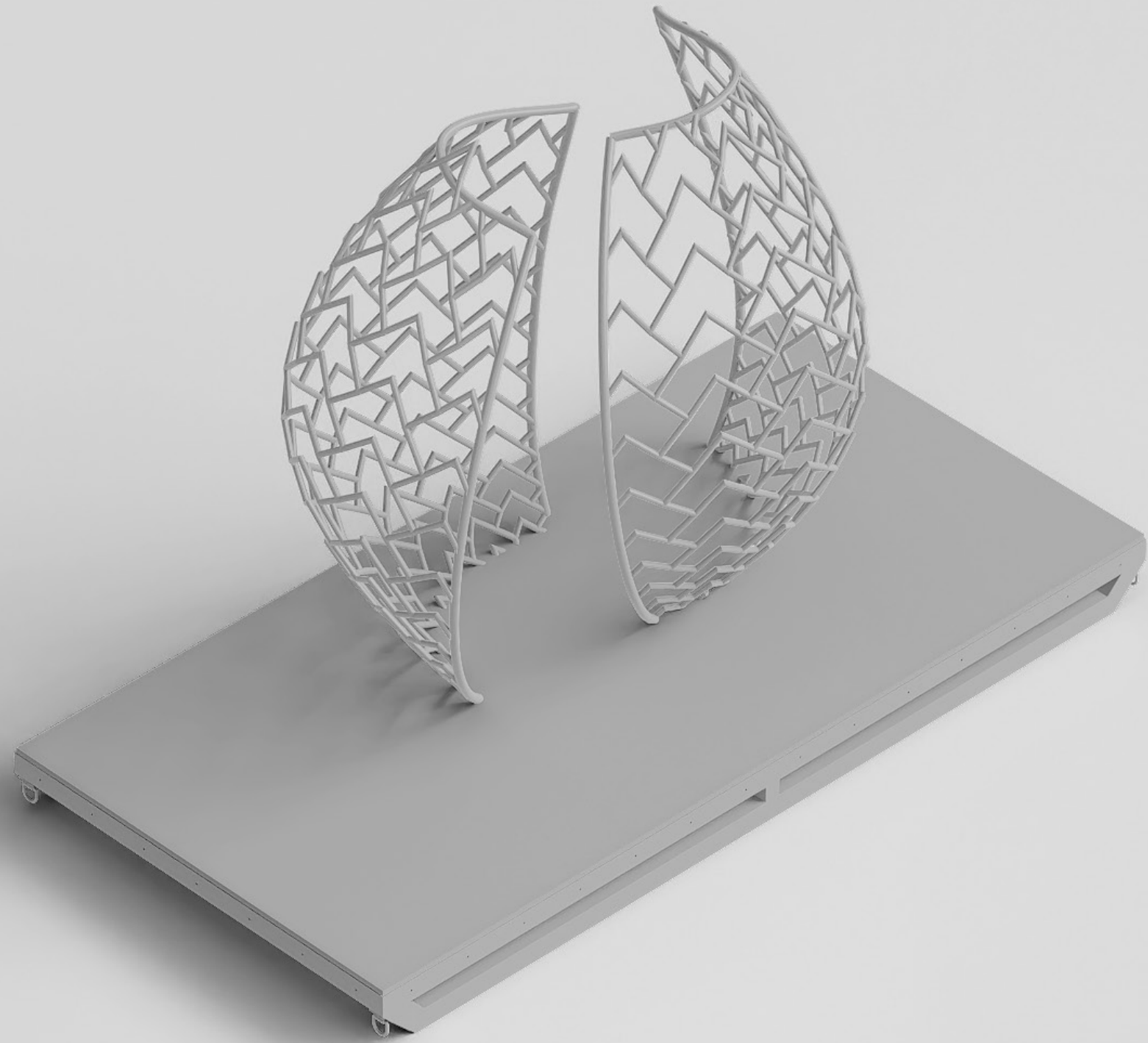



Exterior Daylight

02 International Airport & Transit (Confidential)

Year : 2024
Type : ARUP
Team : Multidisciplinary
Role : Architecture Design Intern
Status: In Progress

As a Design Intern at ARUP, I worked on projects including International Airport and Transit. I was part of a team which specialized in making design decisions. My role was to handle the task of making accurate drawings and making sure that it is being created as what senior designers have suggested. I took care of numerous tasks including handling of Revit files, creating visualizations for initial design report, and learning project administration phase. The transit project had an early design concept of 5%, whereas the airport project had a 30% schematic design. To ensure general functionality, the designs were addressed in collaboration with various disciplines.



03 Library

Year : 2022
Type : Freelance Project
Team : Sole
Role : Architecture Design & Visualization
Status: Completed

Library Design was one of most challenging and excellent job which I have ever done as a Freelancer. Main objective of the project was to create photo-realistic renders with high quality assets. Library was designed with two storeys connected with stairs. A large collection of books. A computer access in the L shaped form, and with that an artificial tree in the middle of three classroom.

Client wanted four interior renders of the space with different perspectives. Each should have the main design covered in it, and every element should light-up when someone watches the image. I went with hand drafting to communicate the design with client, and then went digital to elaborate it further. Design was done in AutoCad first and then transferred to Revit. To visualize the model D5 render was used. Brick columns with tile flooring and white wall board was the theme client agreed to and that was achieved through manipulation of lighting in photoshop.



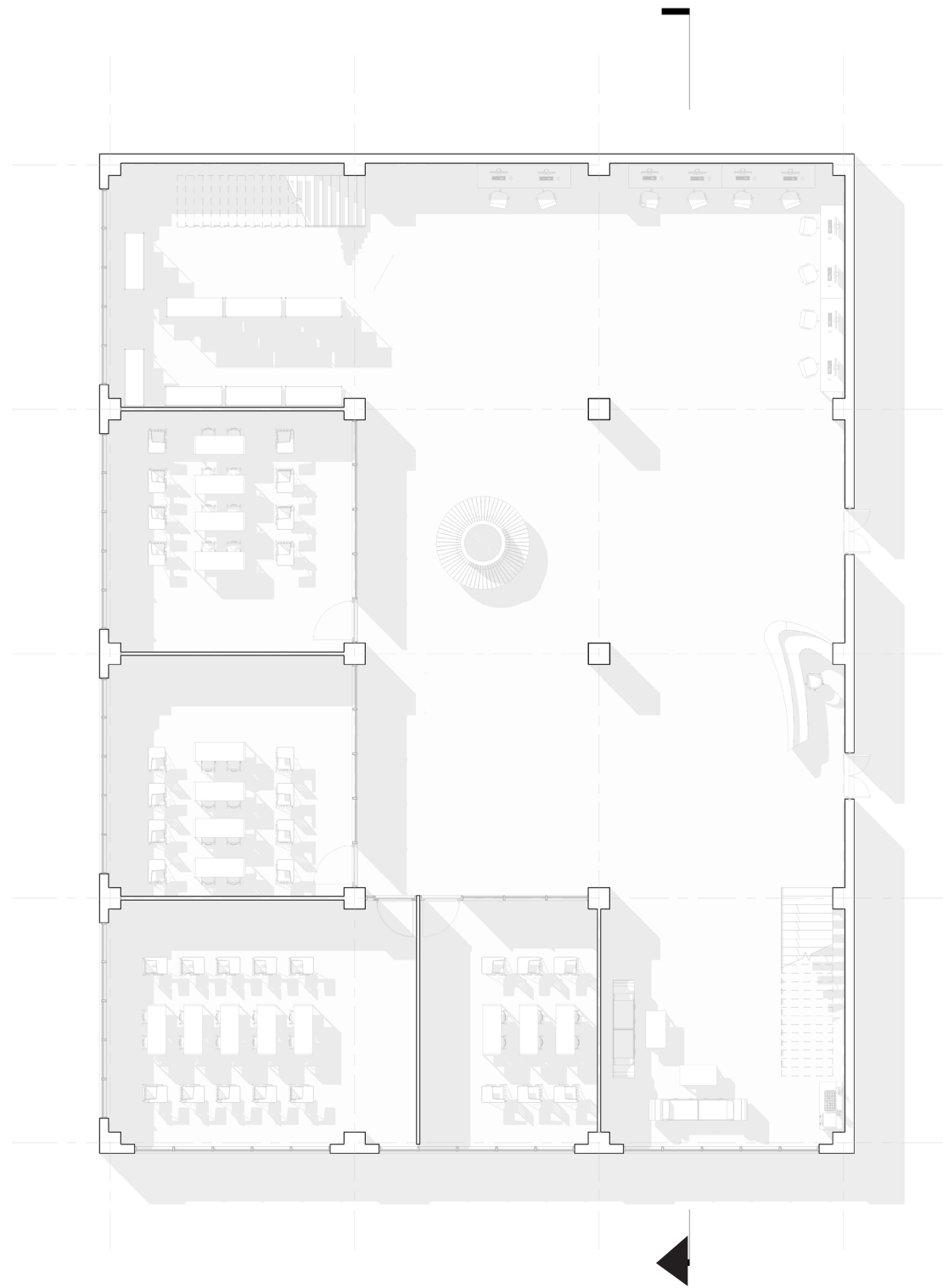

Ground floor

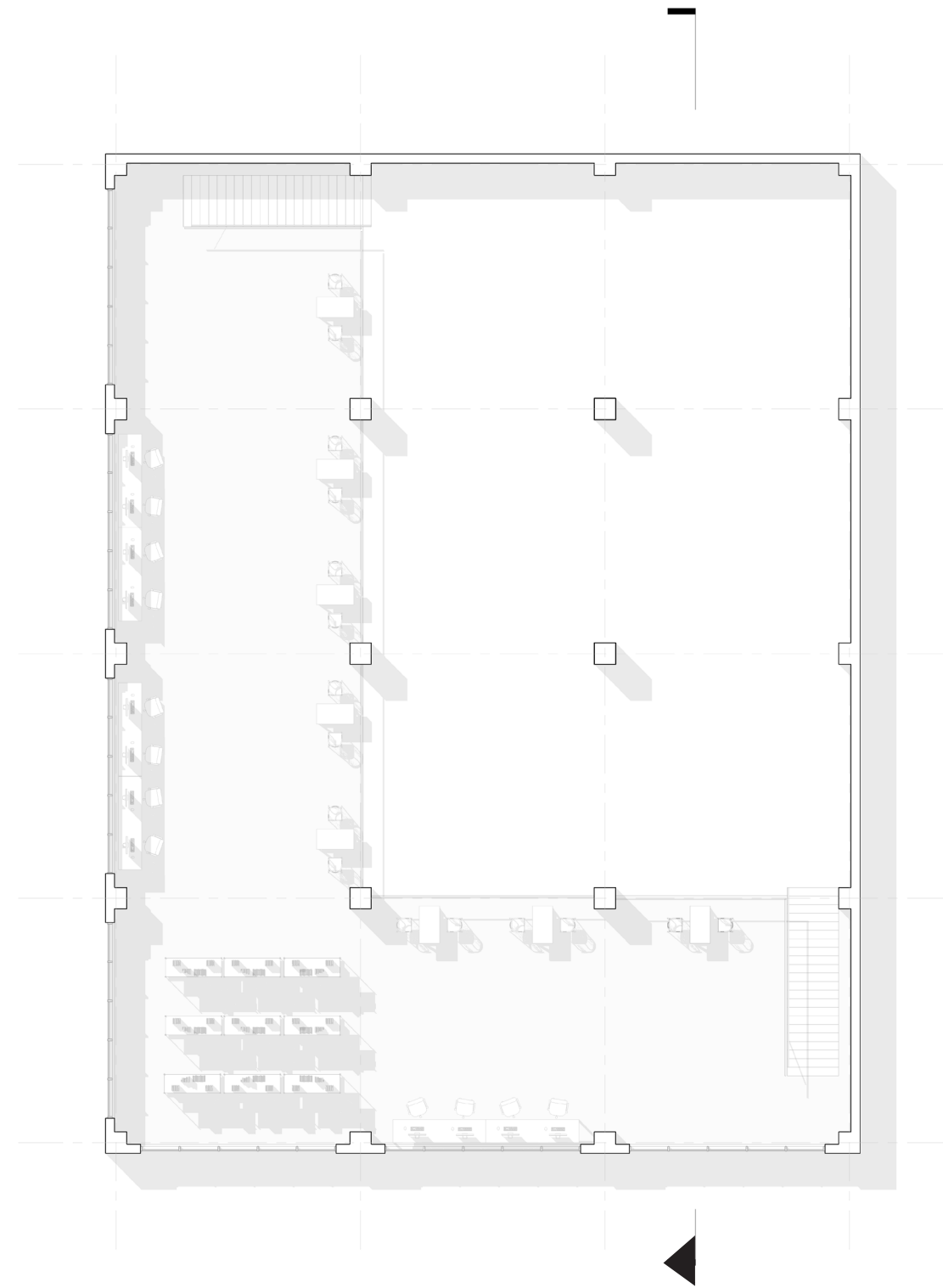

Second Floor

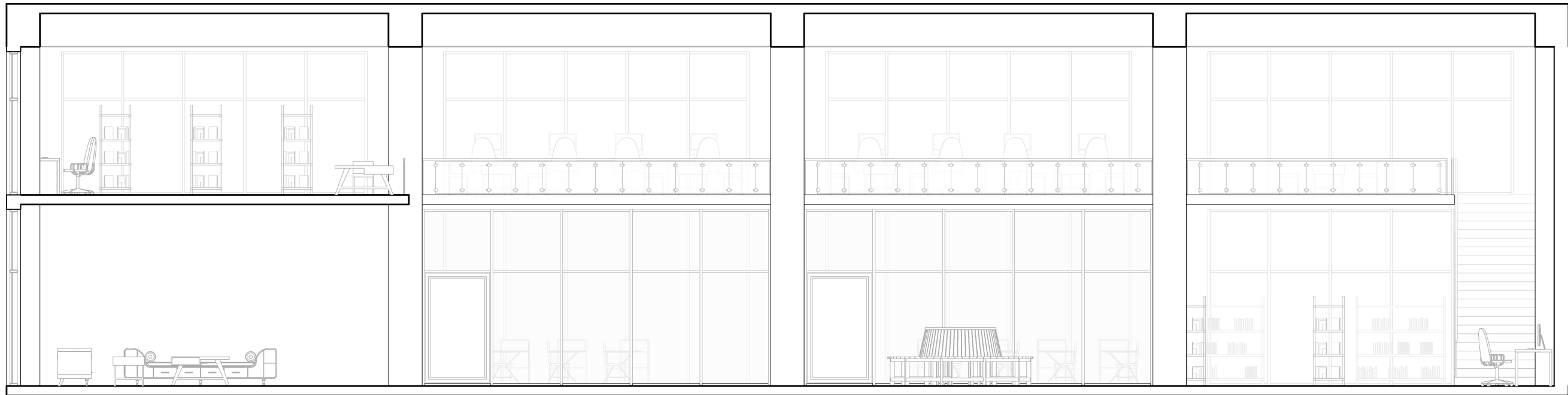



Courtyard Daylight



Coffee Corner



04 Administration Building

Year : 2024
 Type : Algonquin's Educational Project
 Team : Sole
 Role : Architecture Technician
 Status: Completed

Hydro One is Ontario's largest electricity transmission and distribution service provider. They require as new business administration building to support the Southwestern Ontario region. They have recently acquired a property located at 1990 Oxford Street East, in the City of London, Ontario. This location was formerly a landscaping supply store. They want to include a sustainable green roofing system, accessible to building occupants and provide a combination of surface and underground parking. The ground level will be leased as commercial space to offset some of the building operation costs and to integrate the building as part of the local community.

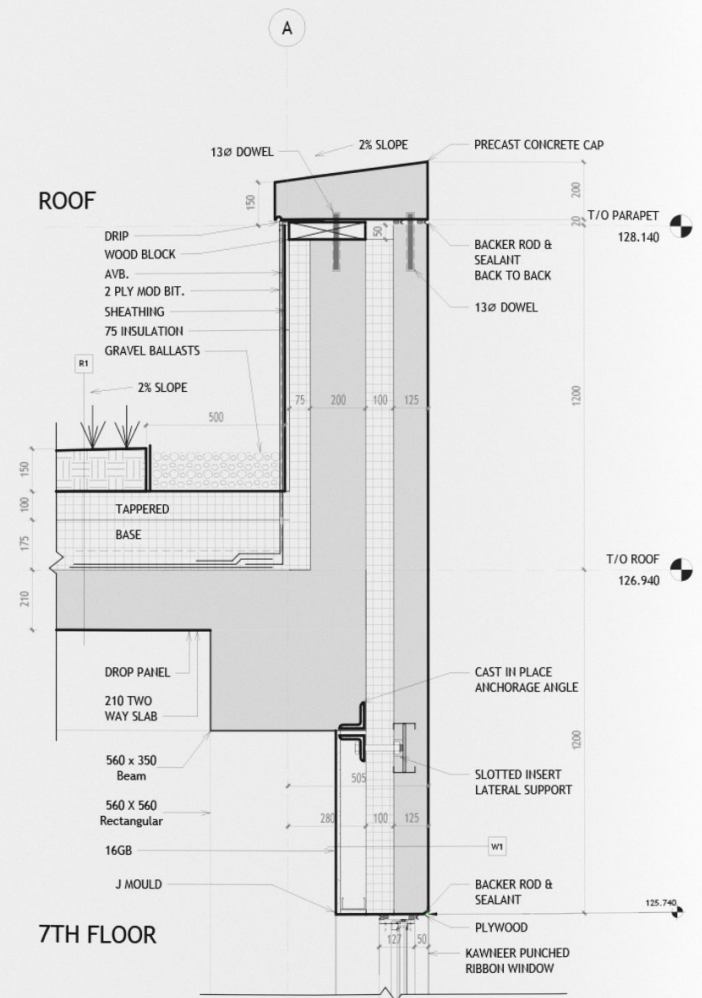

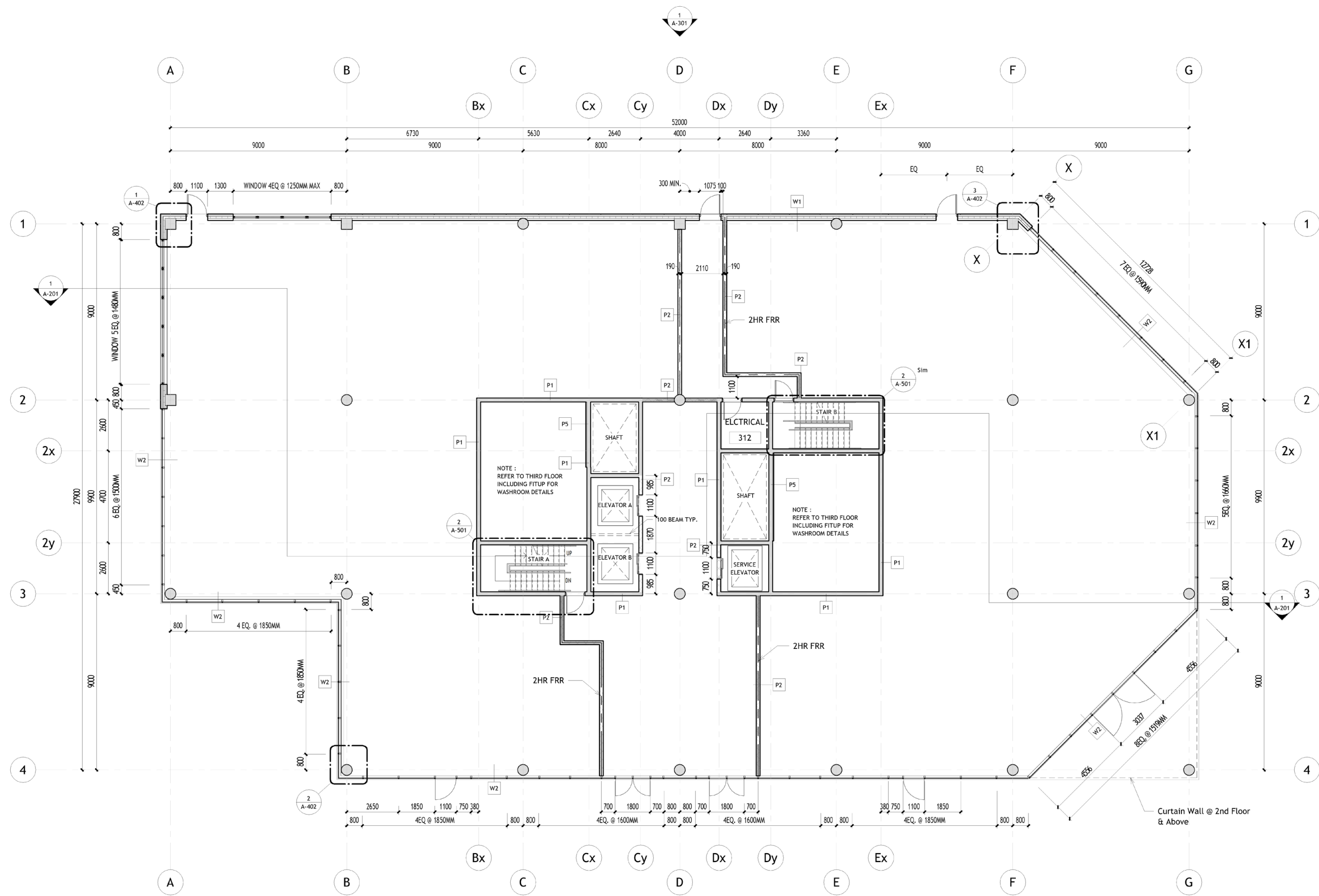

Ground Floor Plan

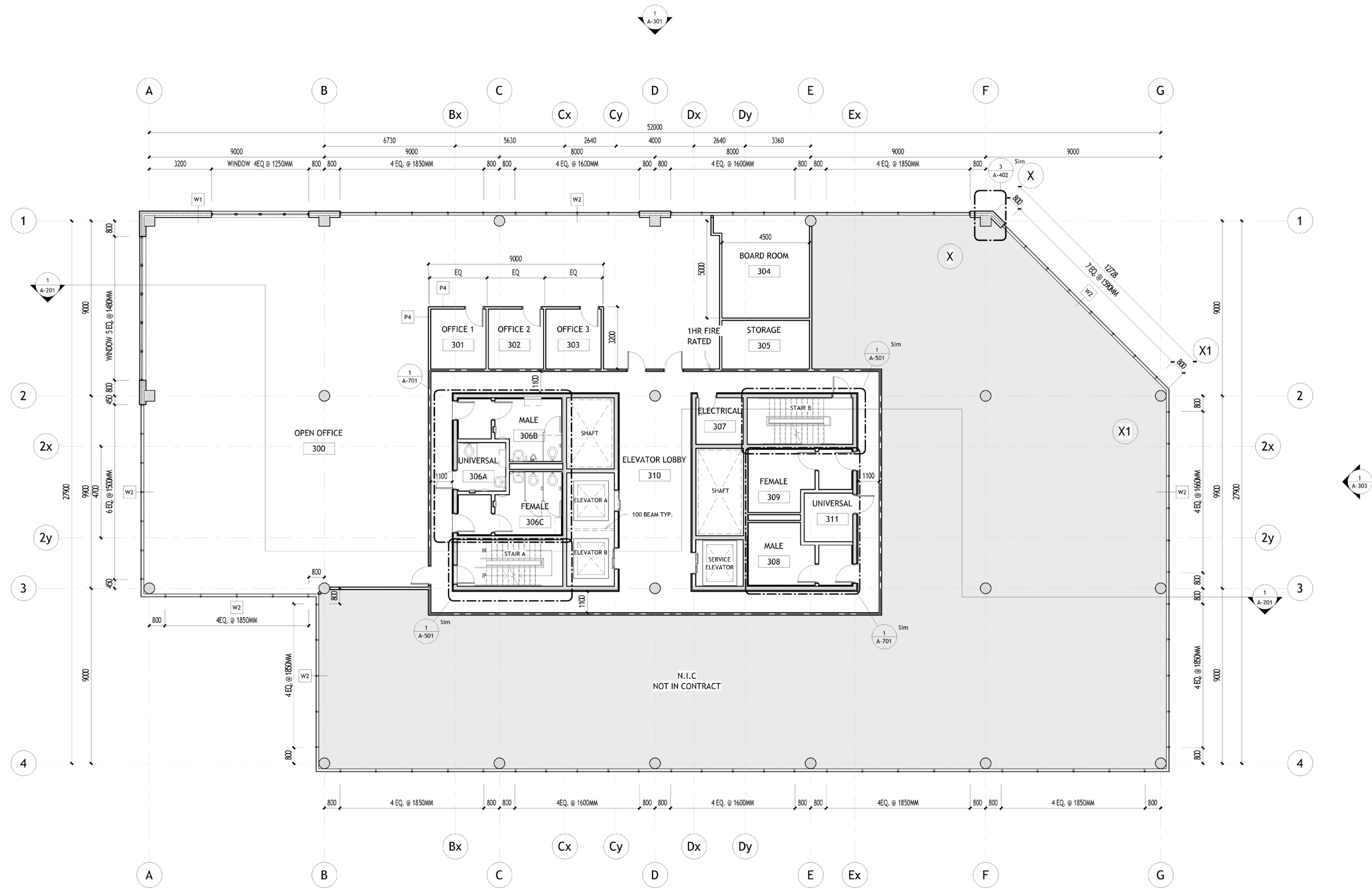

Third Floor (Fit-up)

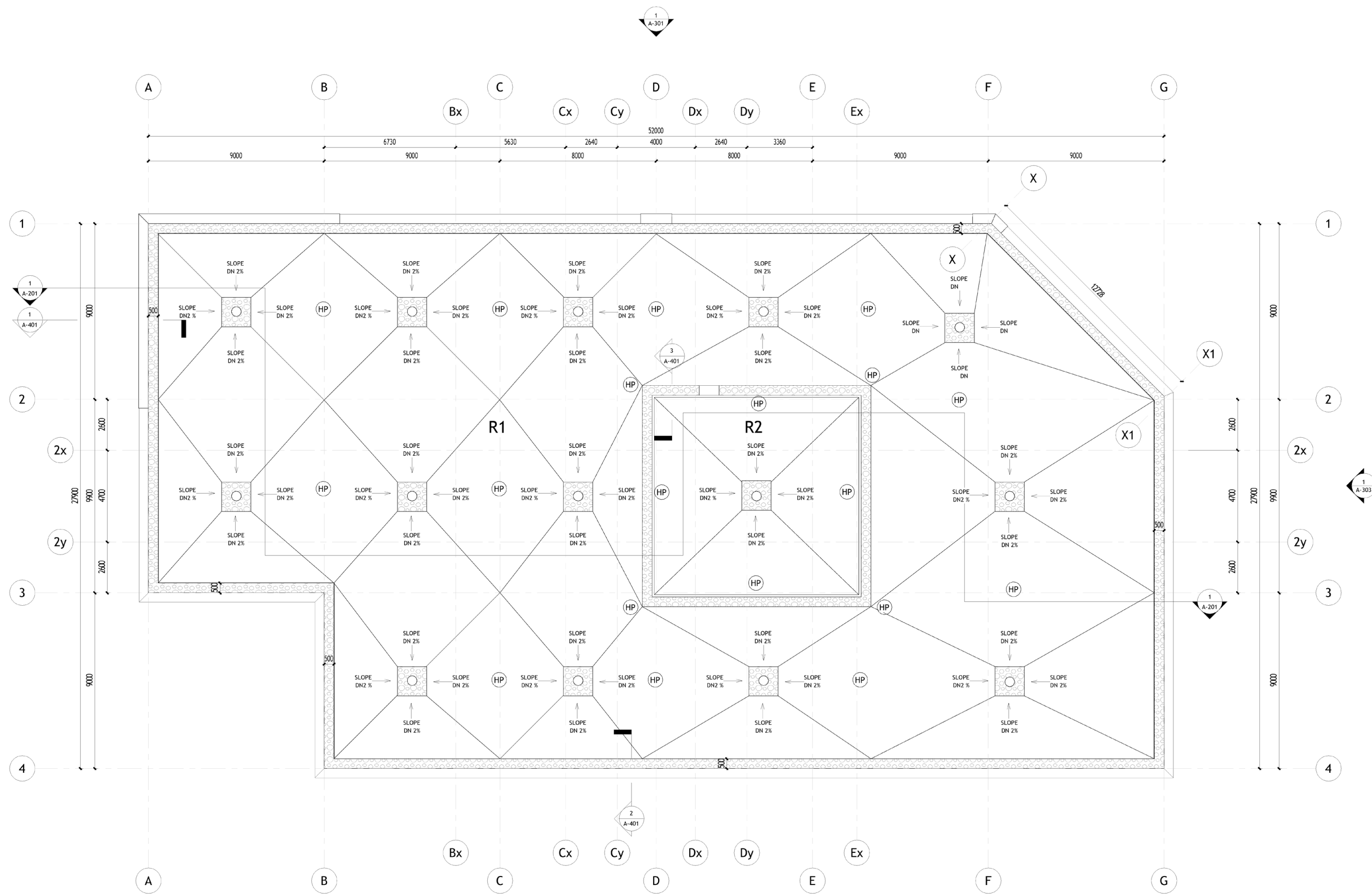

Roof Plan

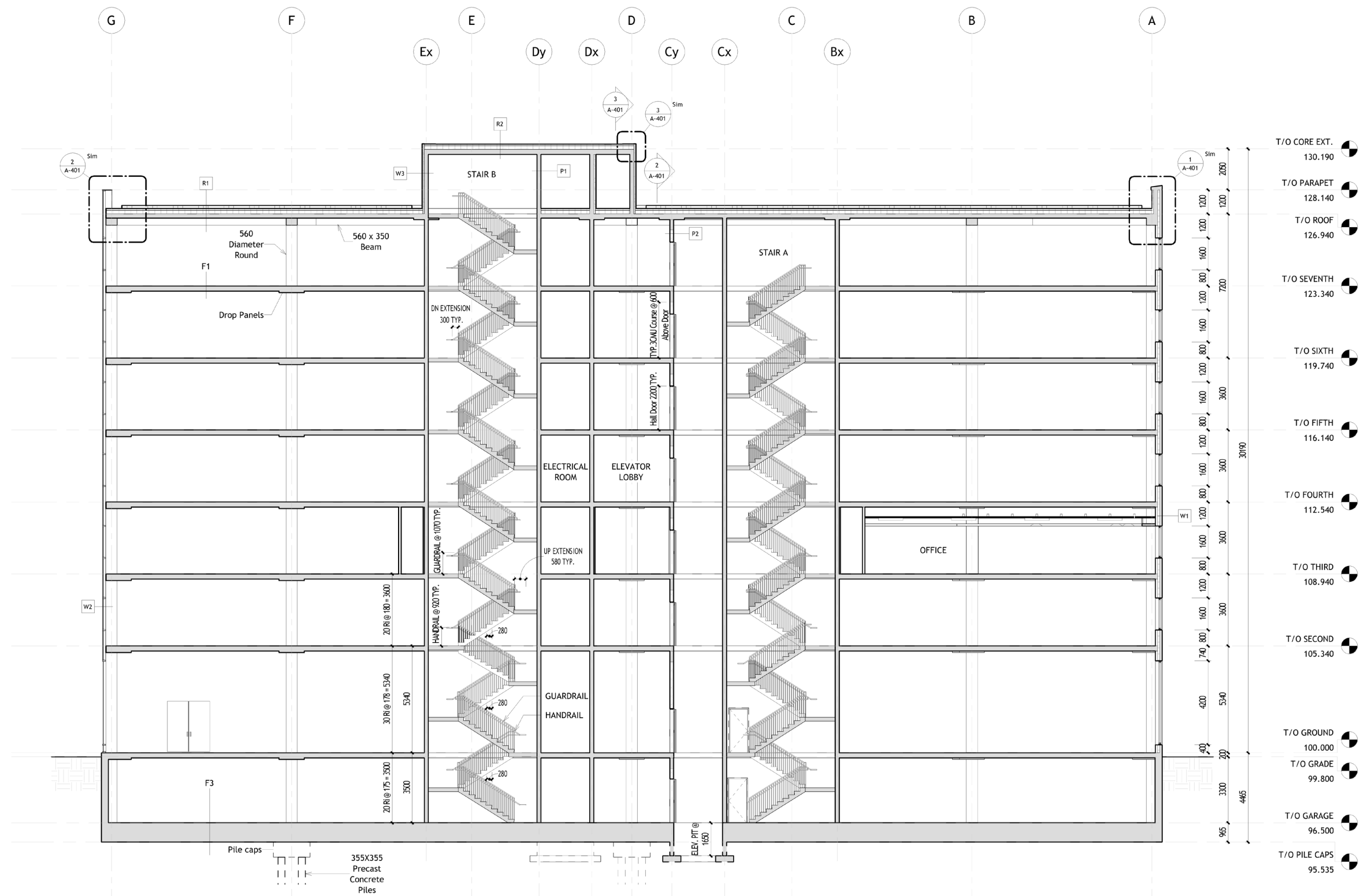

Building Section

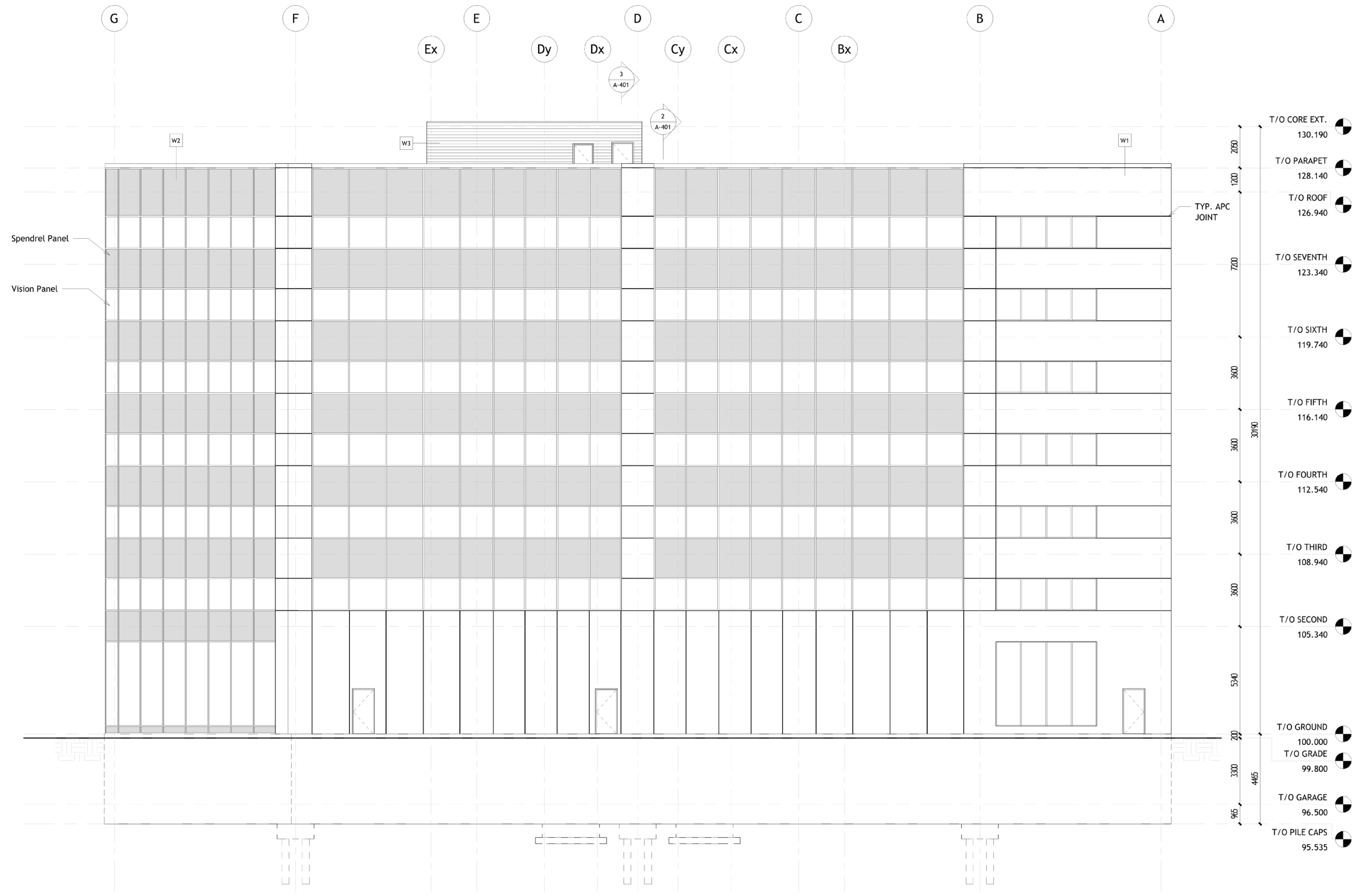

North Elevation

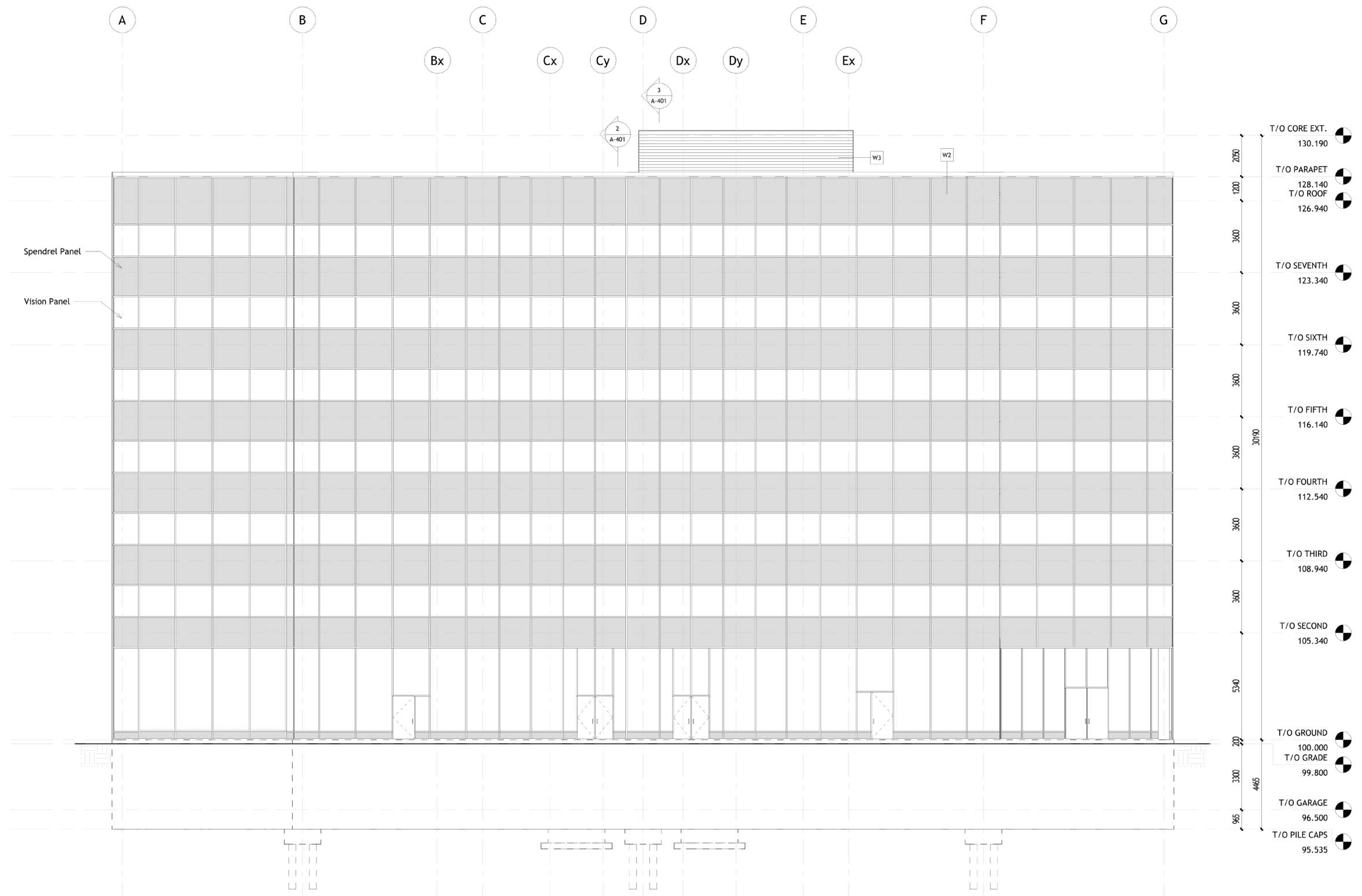

South Elevation

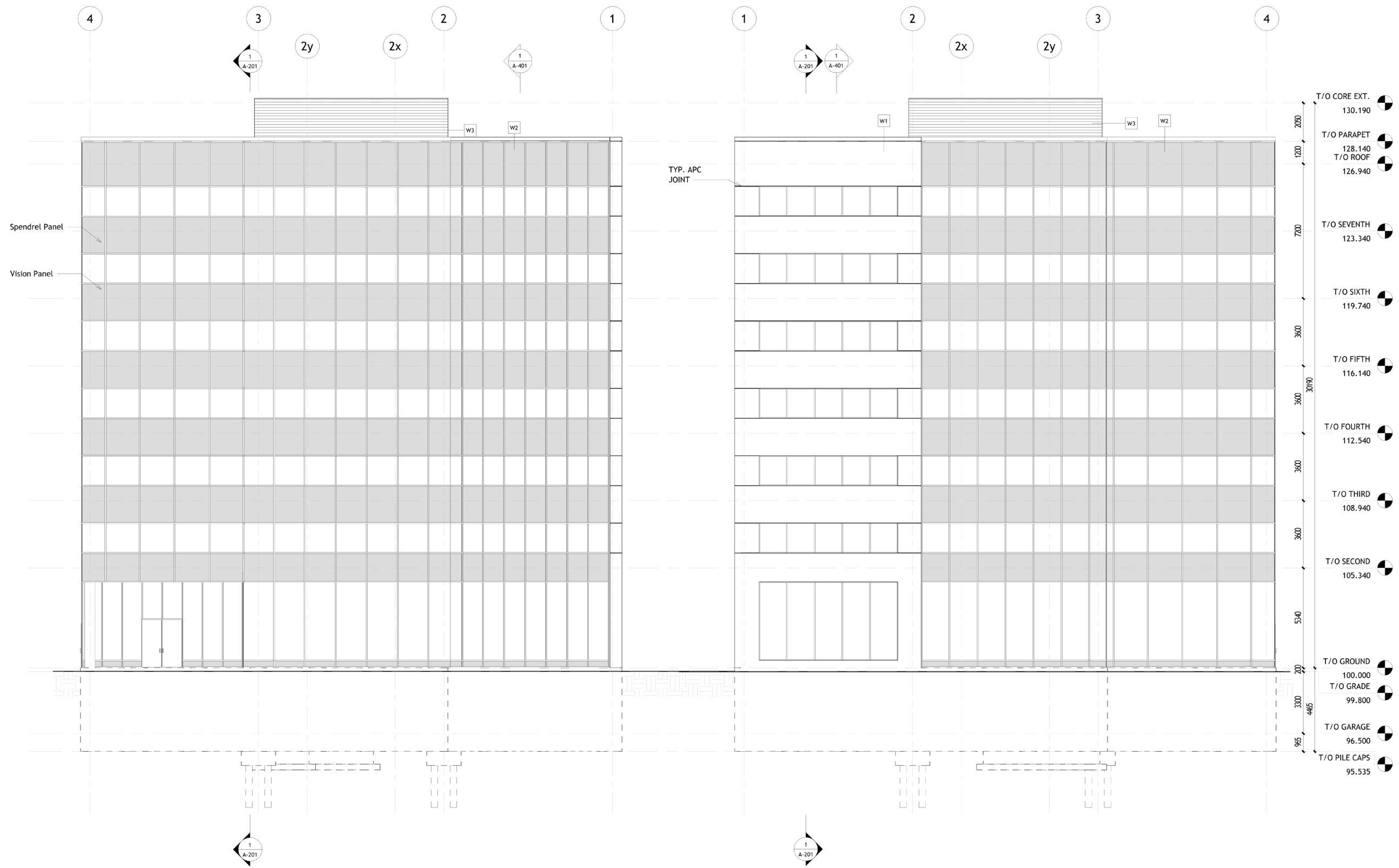

East Elevation

West Elevation

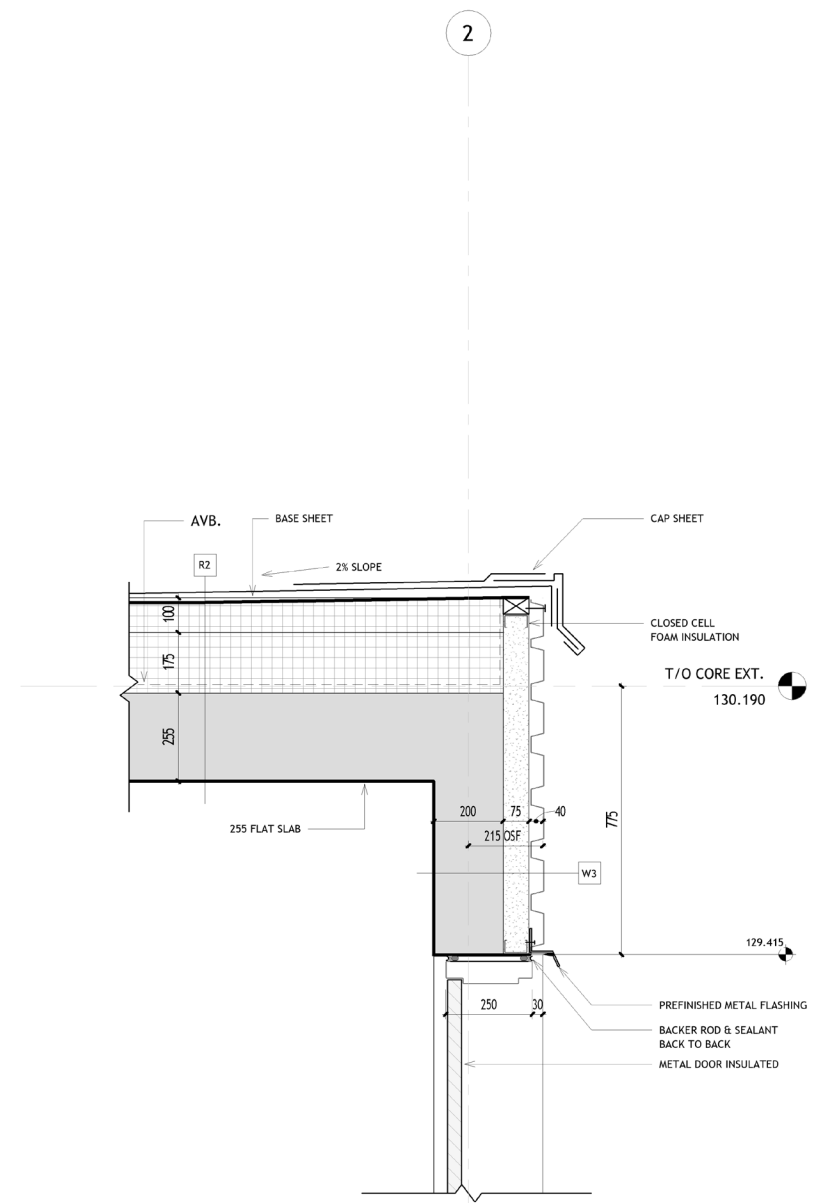
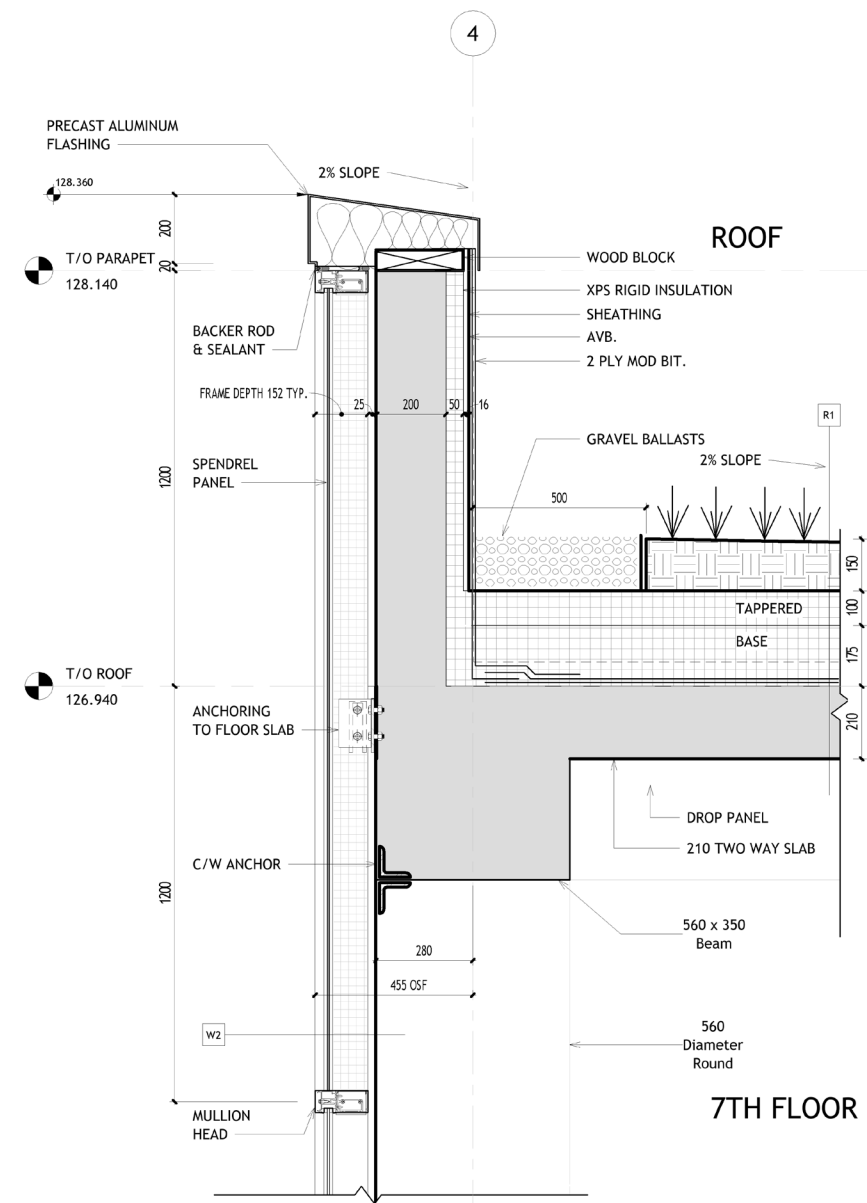
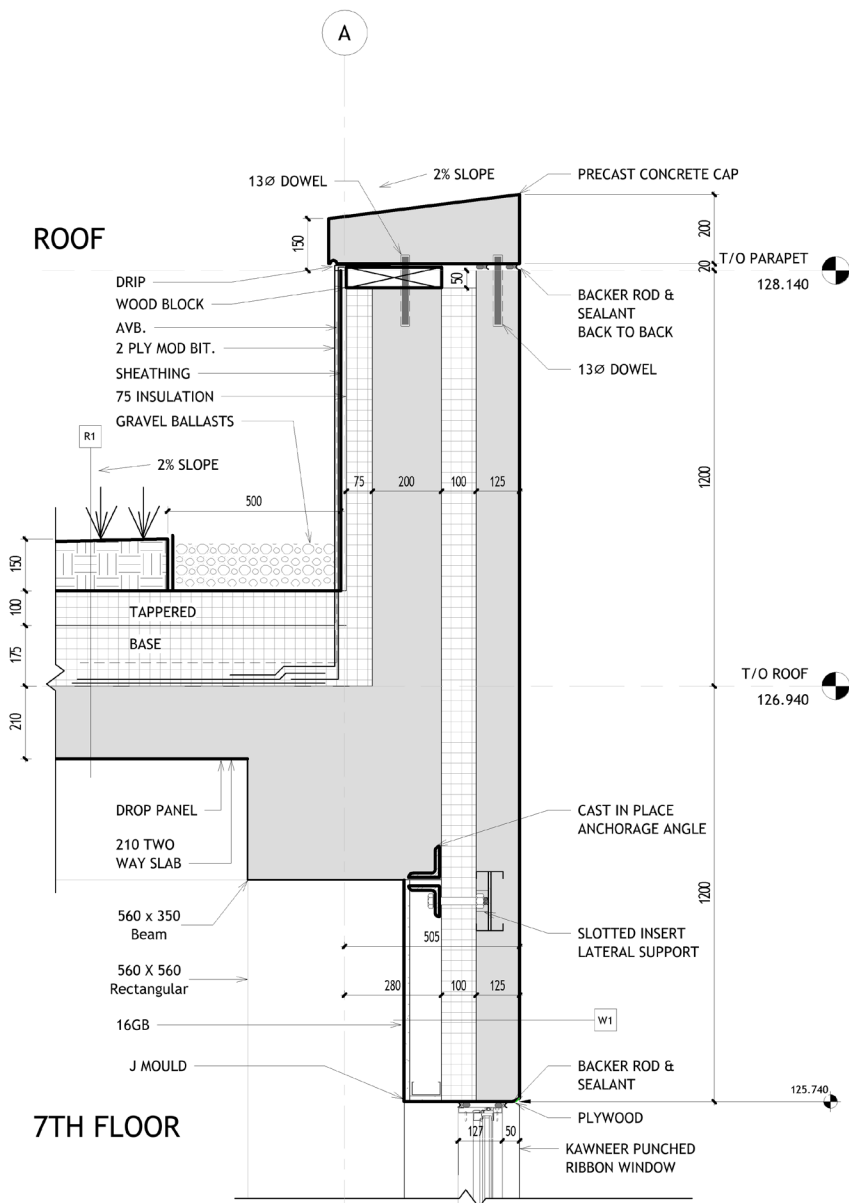

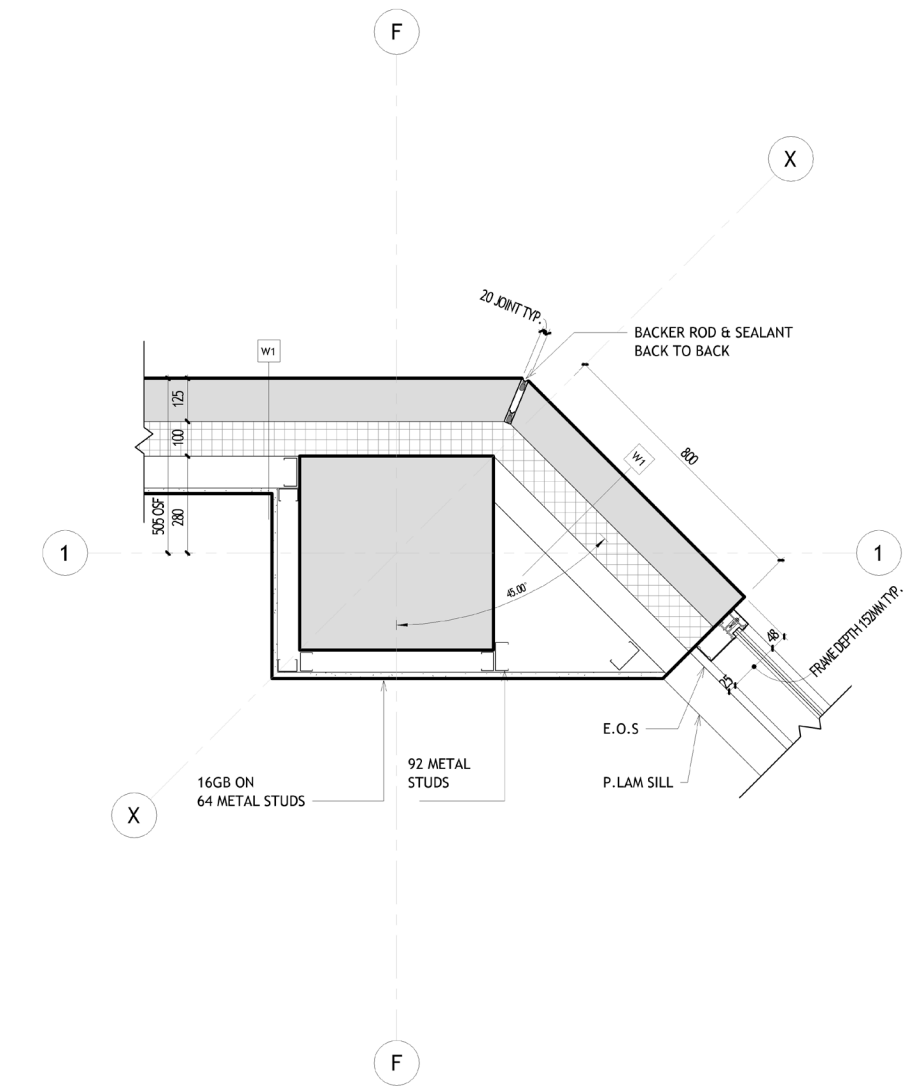
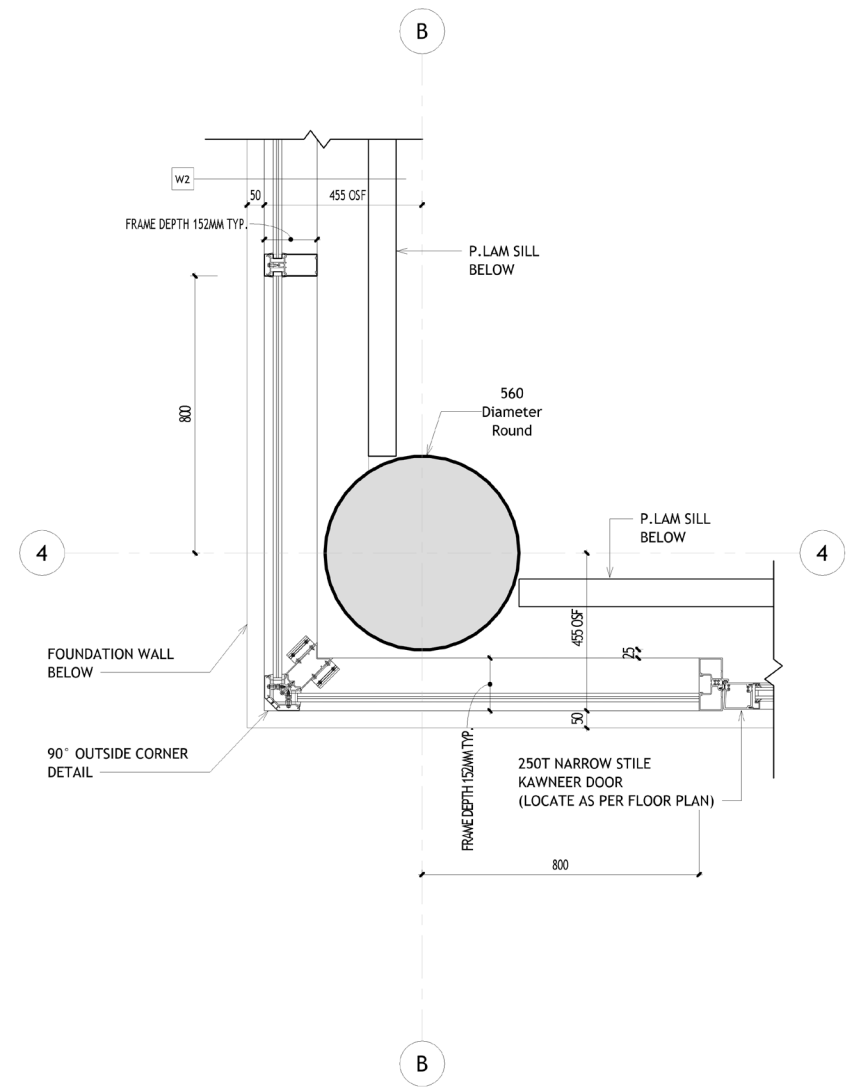
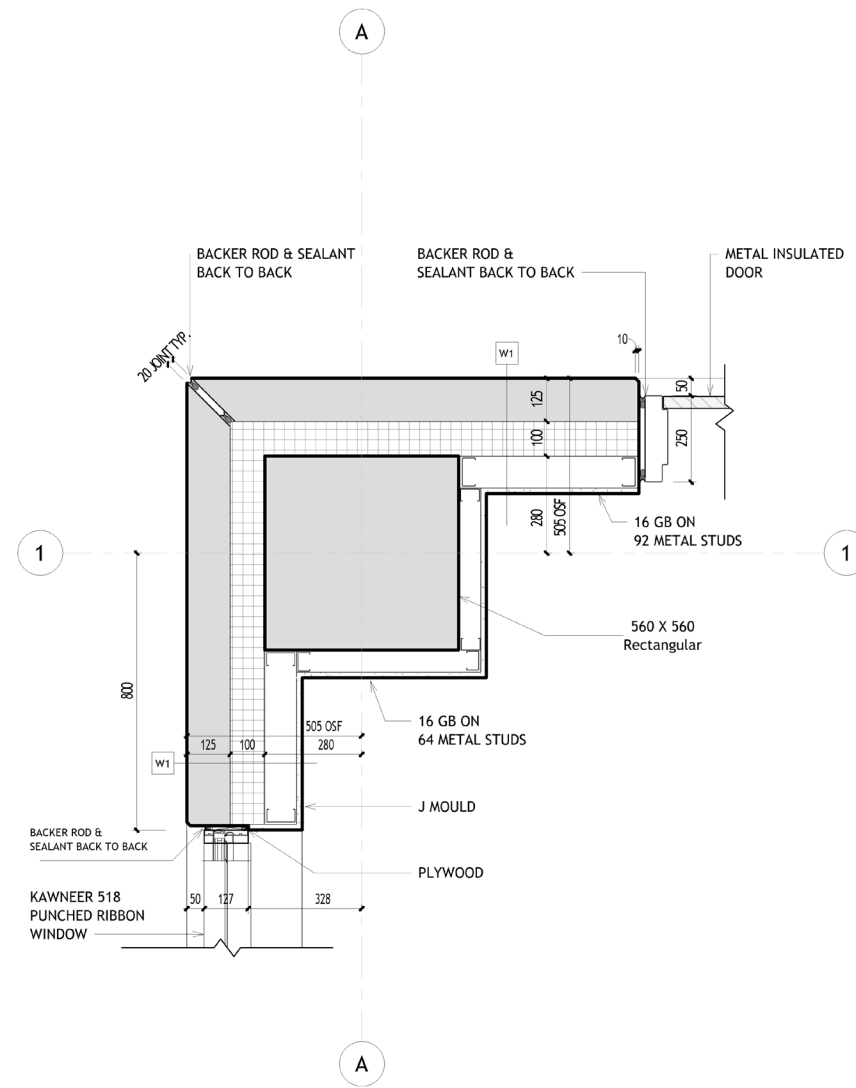

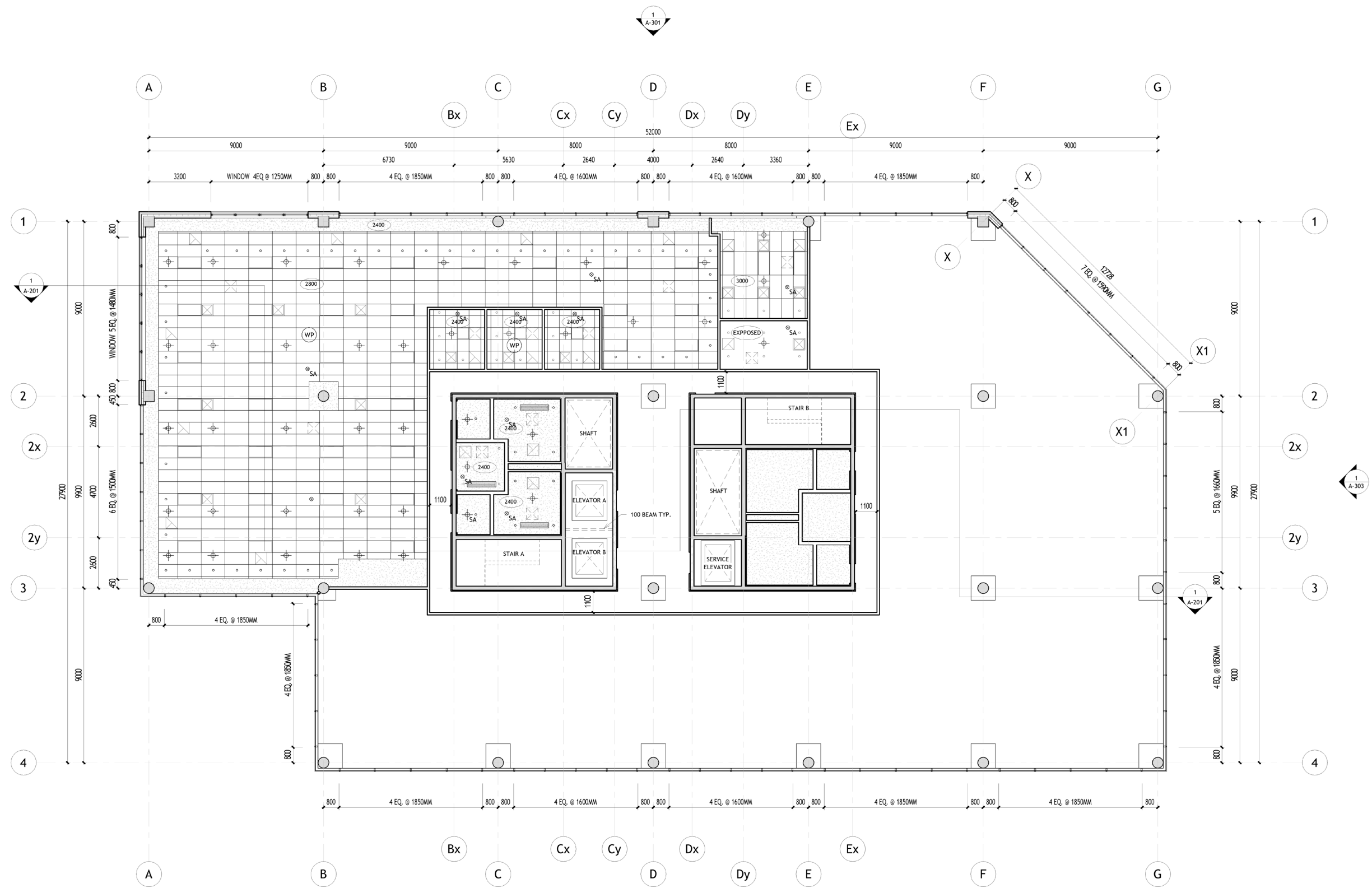

Reflected Ceiling Plan

05 Retreat House

Year : 2023
Type : Algonquin's Educational Project
Team : Sole
Role : Architecture Design
Status: Completed

Retreat House was a project nearby Muskoka lake. The site was on a sloping ground with existing vegetation. I was given a task to create a retreat house which would simplify the current usage and which would create a space where the client want to spend their time. Having constraints such as slopped roof, not having excavation, and consider the current positioning of the trees, the project it self was challenging and required lot of thinking. Had looked the barn design from various sources, I decided to go with a simple structure which integrates with the sloping ground and which talks with the environment with the choice of materials.



- 1 Entry
- 2 Living room
- 3 Kitchen & Dining
- 4 Washroom
- 5 Master Bedroom
- 6 Guestroom
- 7 Conservatory
- 8 Deck
- 9 Outdoor space

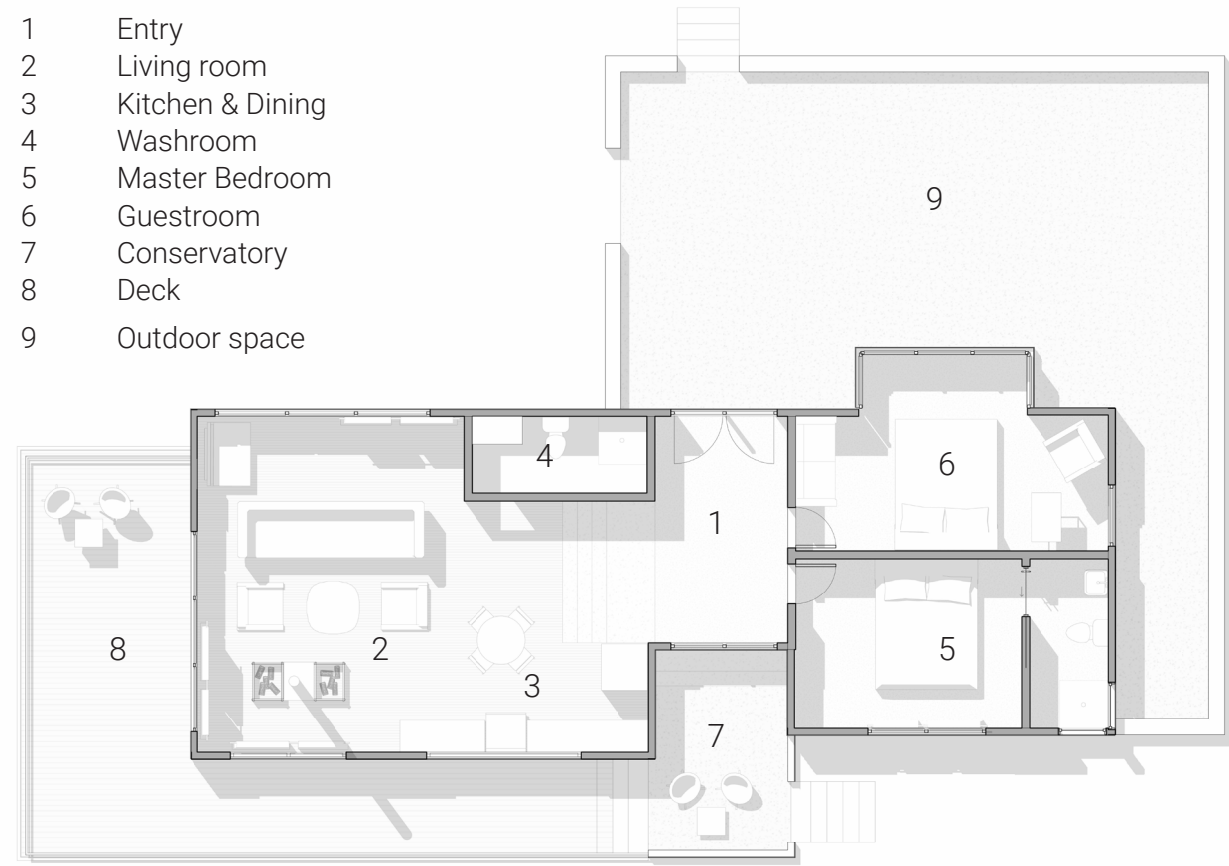

Floor Plan



Section

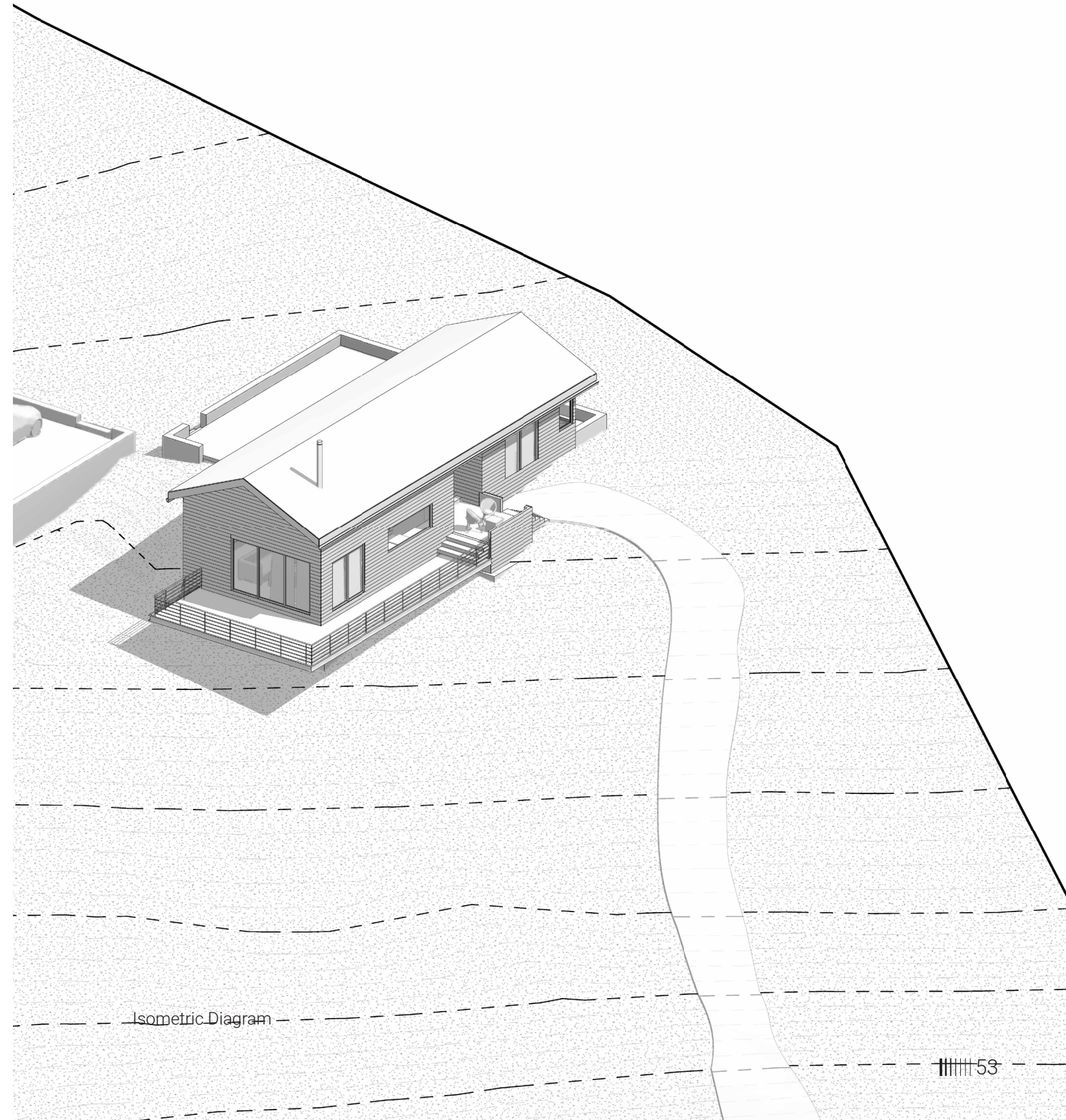

Isometric Diagram

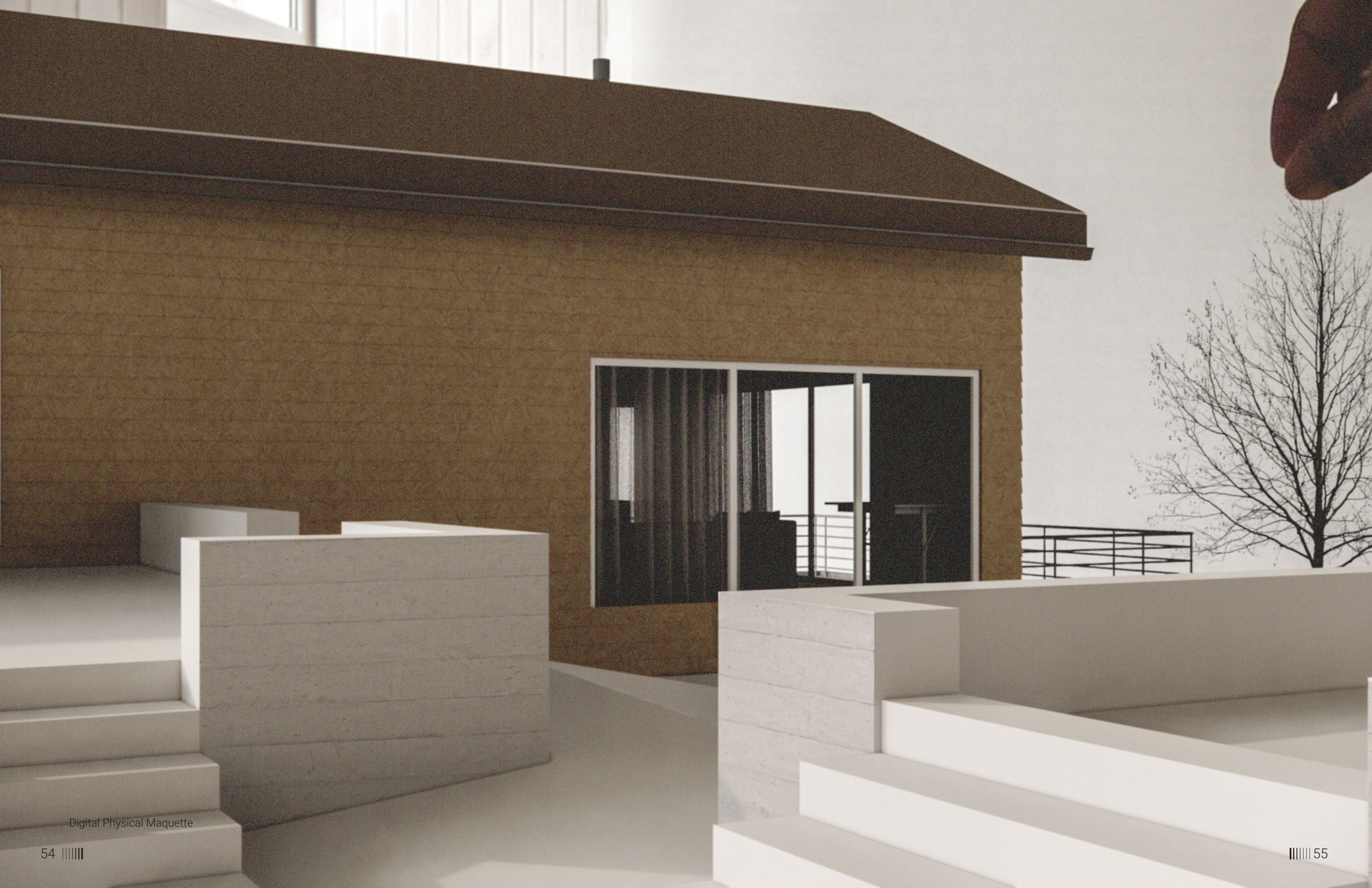



Exterior Evening





Bedroom Daylight

06 Province of Ontario Equipment Repair Facility

Year : 2024
 Type : Algonquin's Educational Project
 Team : Sole
 Role : Architecture Technician
 Status : Completed

Province of Ontario Equipment Repair Facility is a project located in Kingston Ontario. In the final Level of studies we were introduced to this project which was a Storage facility with the office buildings. The classification of the building was 'F1' with offices as 'D'. The task was to understand the construction assemblies and how are placed together. I started with hand sketching and went on digitally to create accurate Revit model which contains every major connection of the construction assembly. I created hand sketches, did calculations for the stairs, filled the OBC data matrix, and generated a sheet set for the drawings. Revit and AutoCad were mainly used to produce the details as necessary.

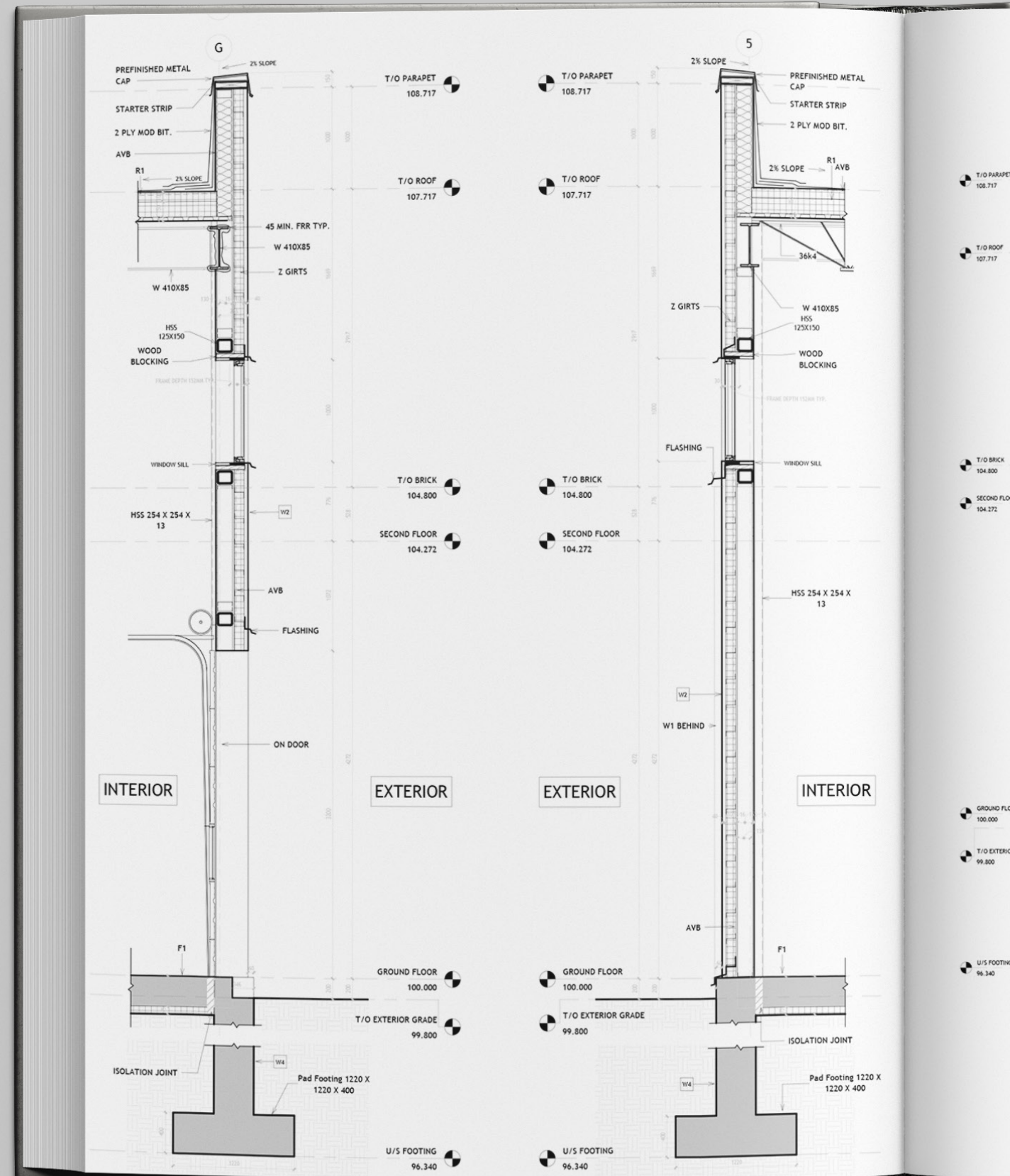

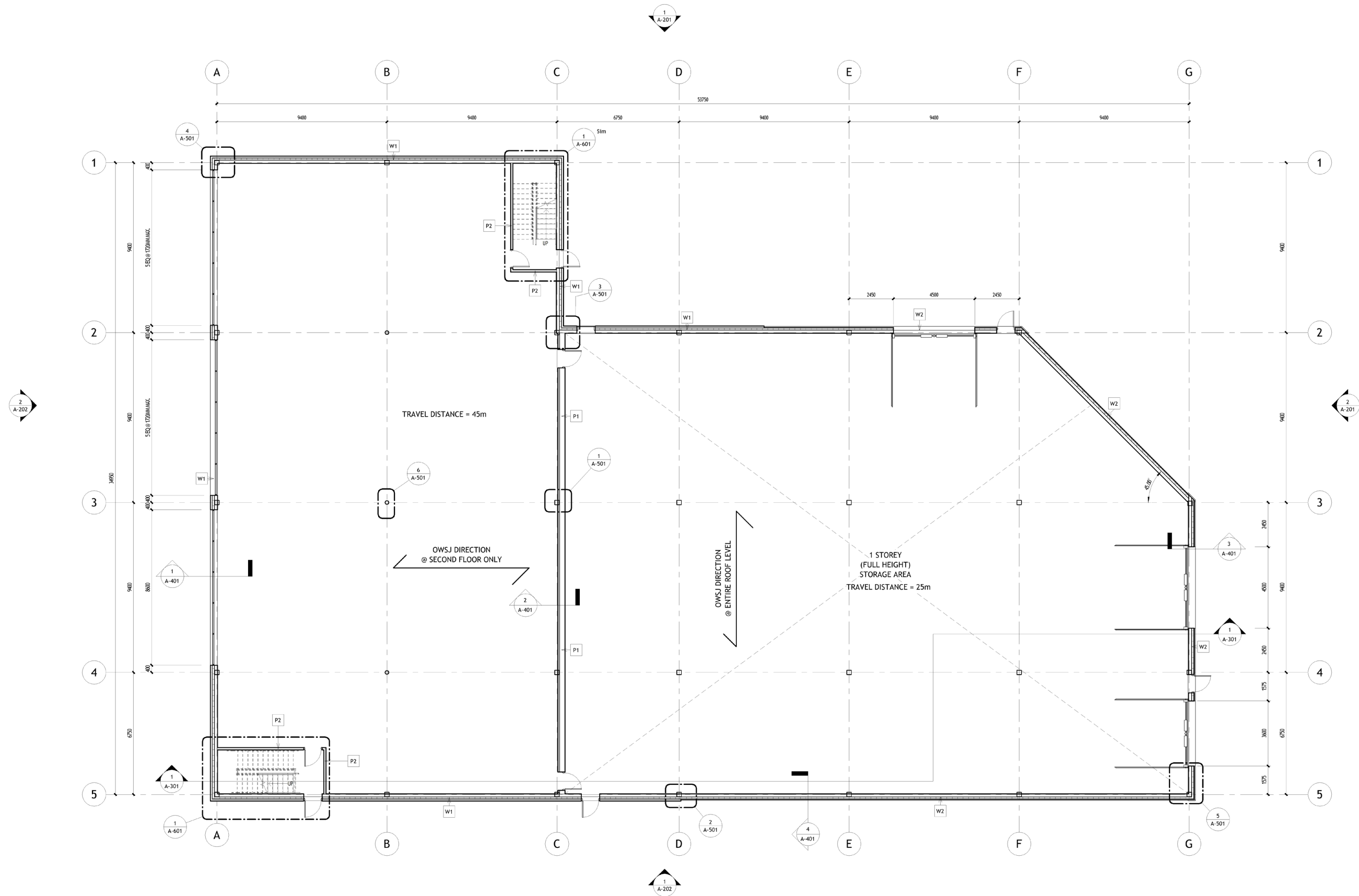

Ground Floor Plan

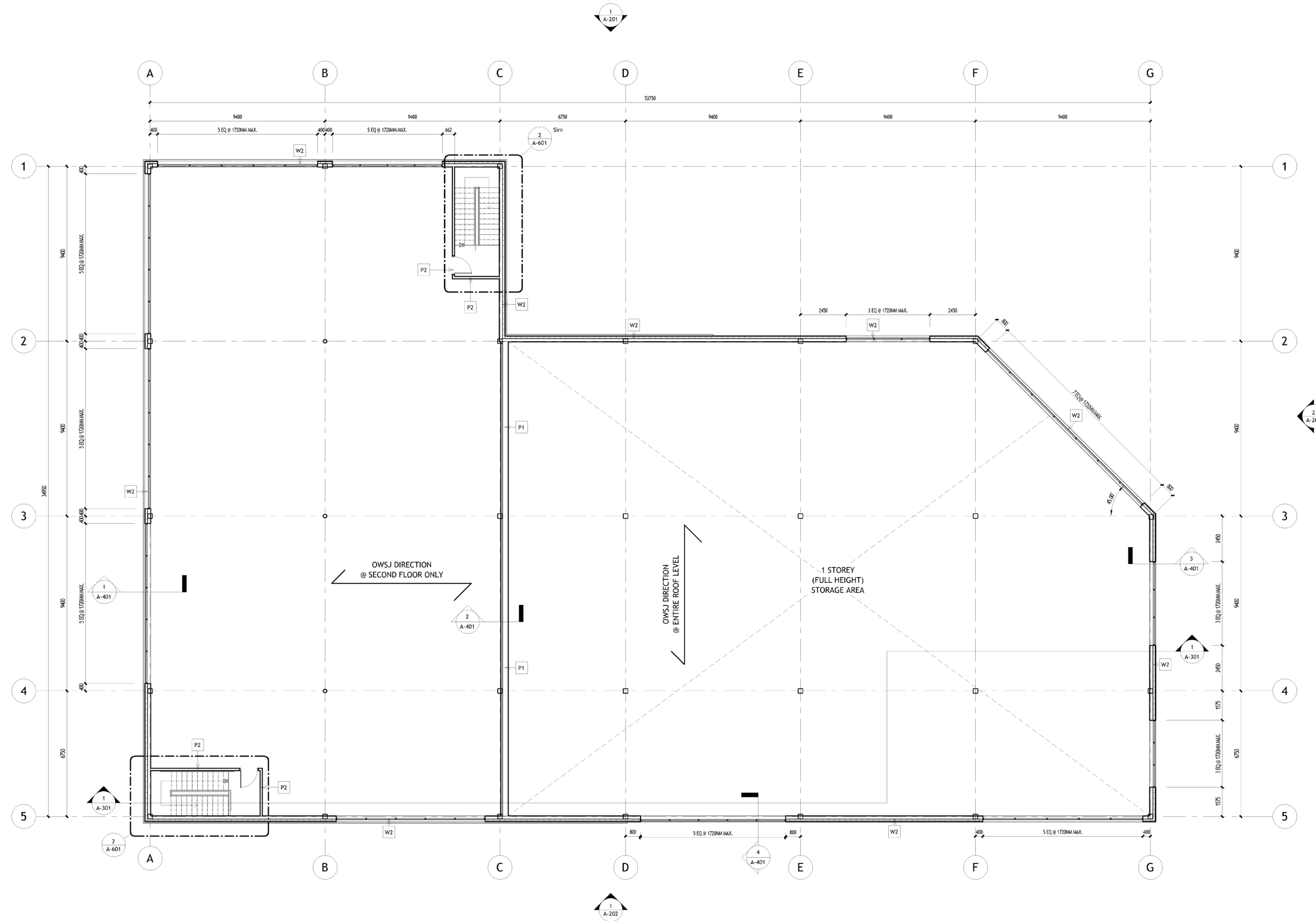

Second Floor Plan

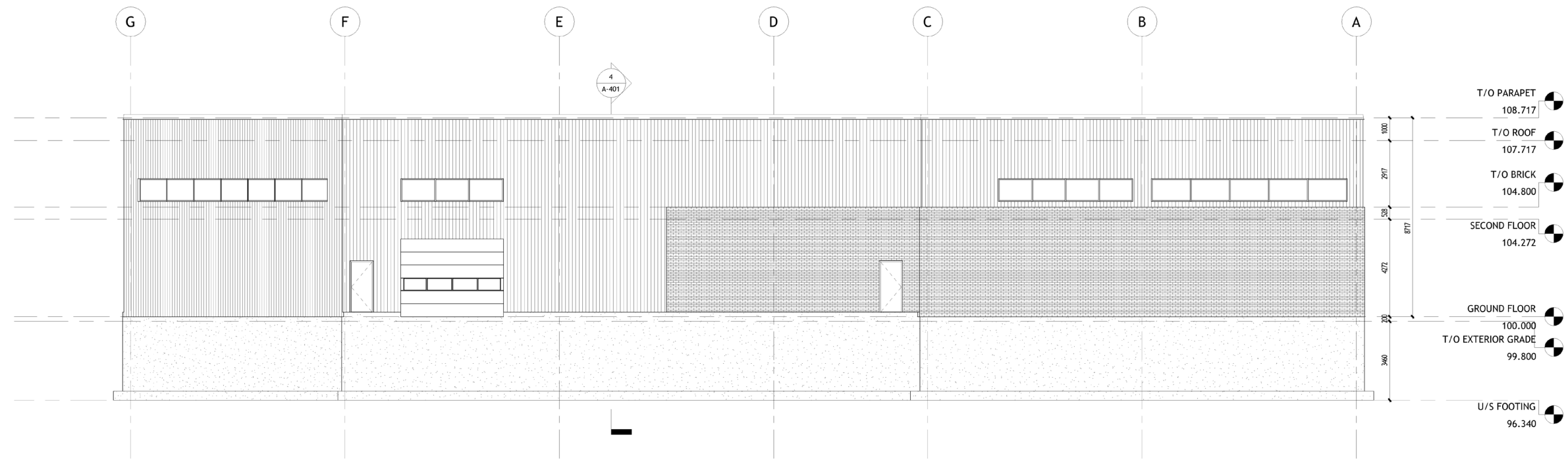

North Elevation

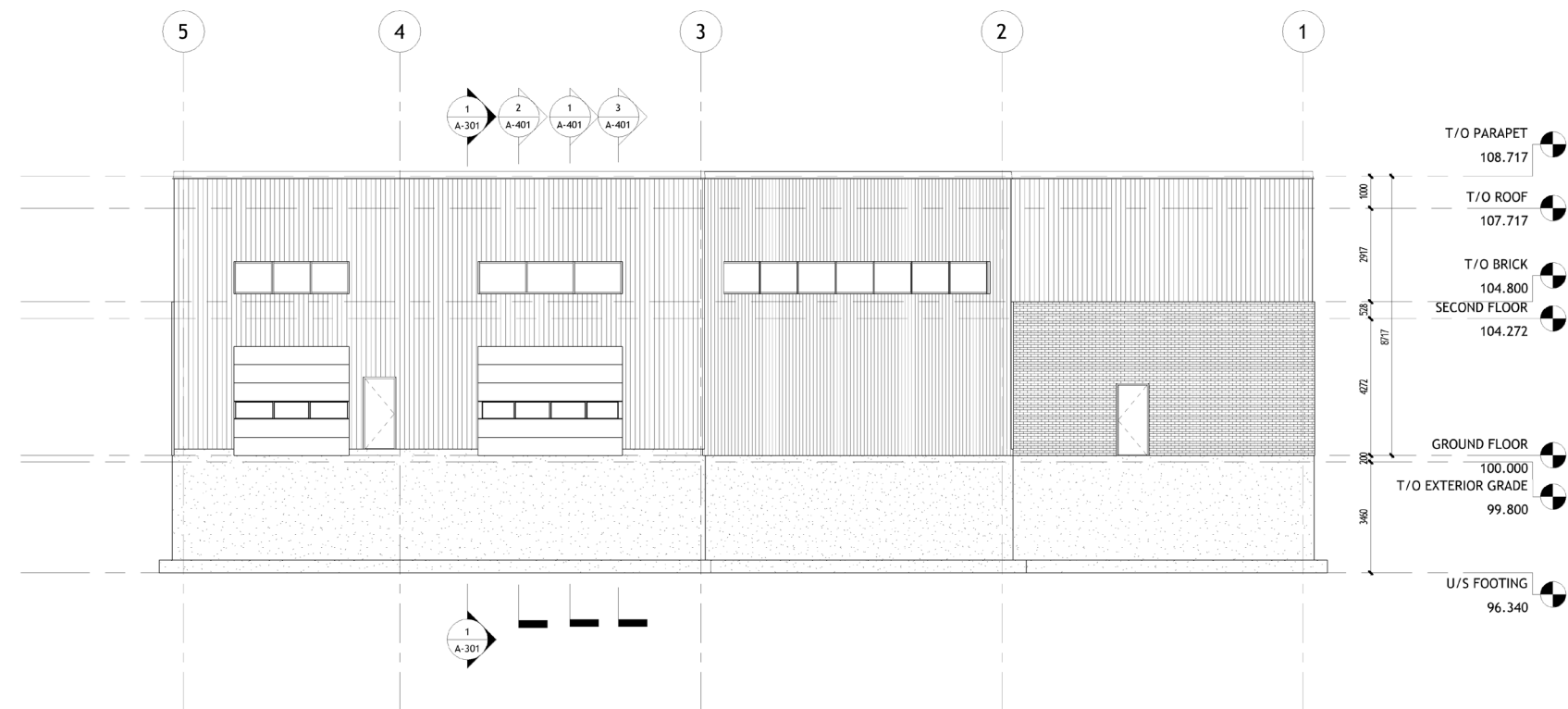

East Elevation

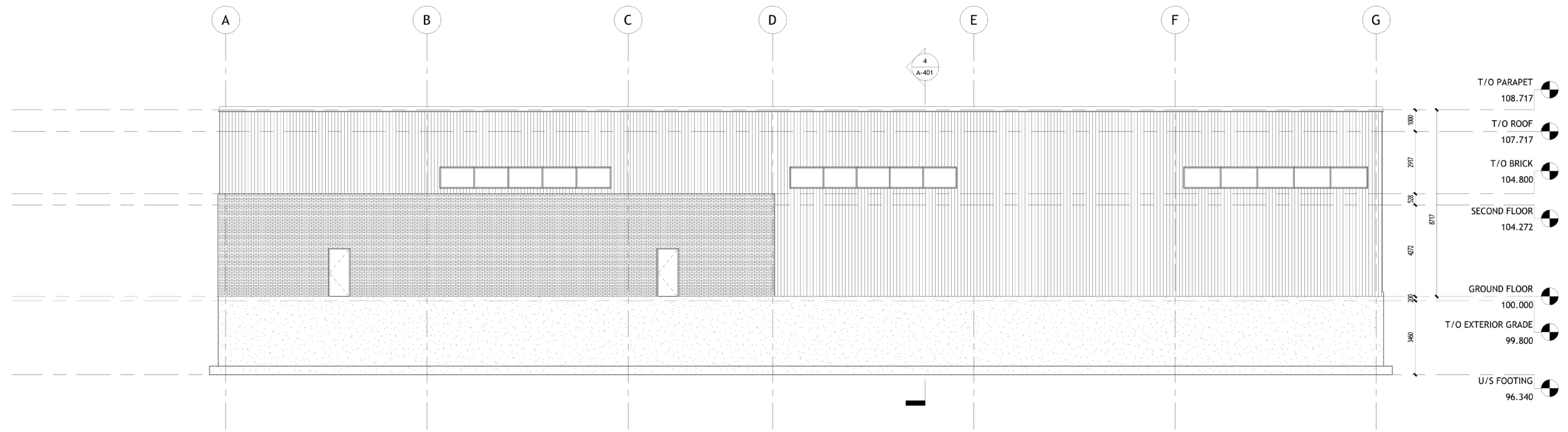

South Elevation

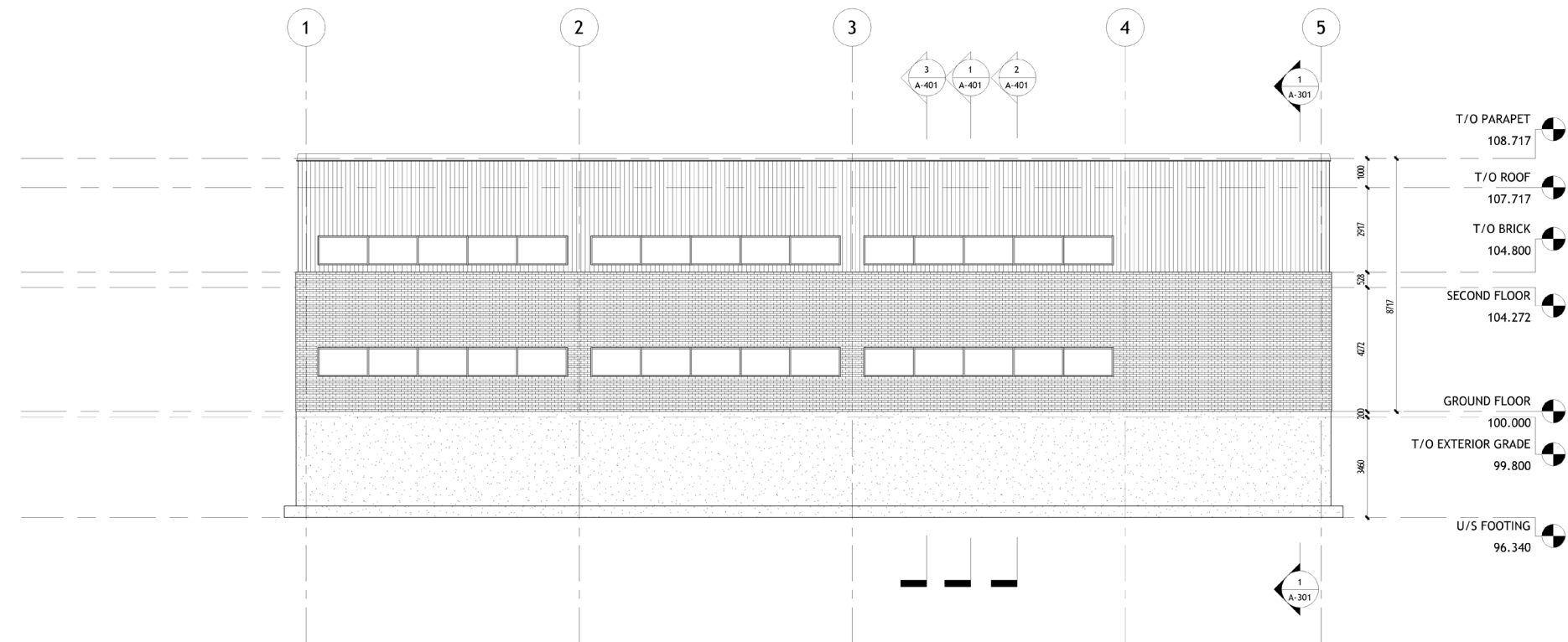

West Elevation

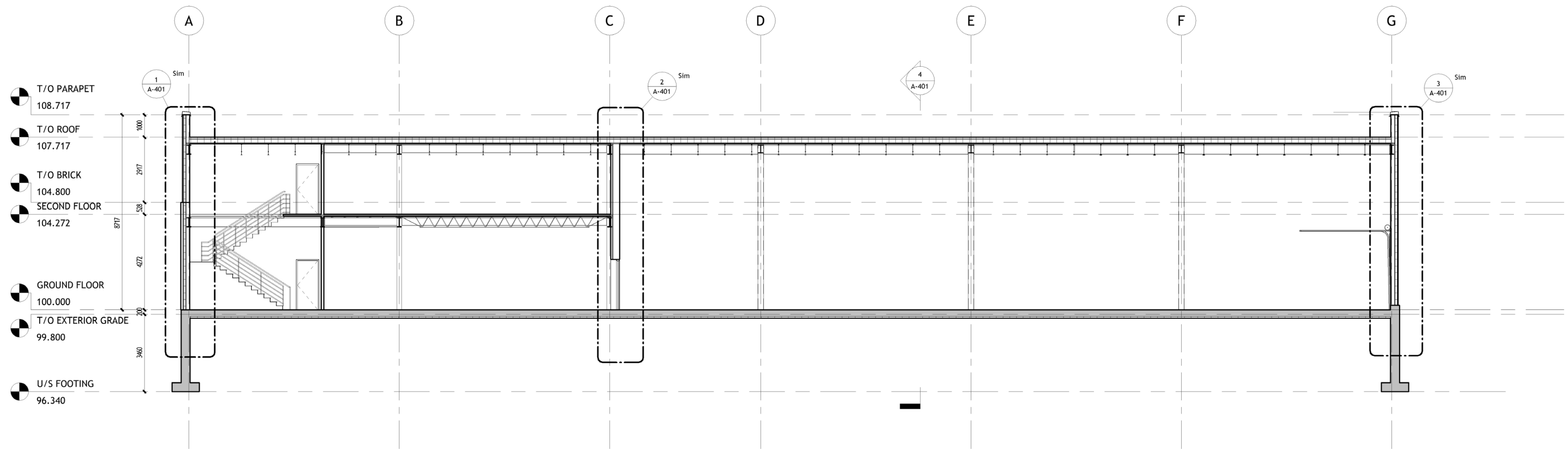

Building Section

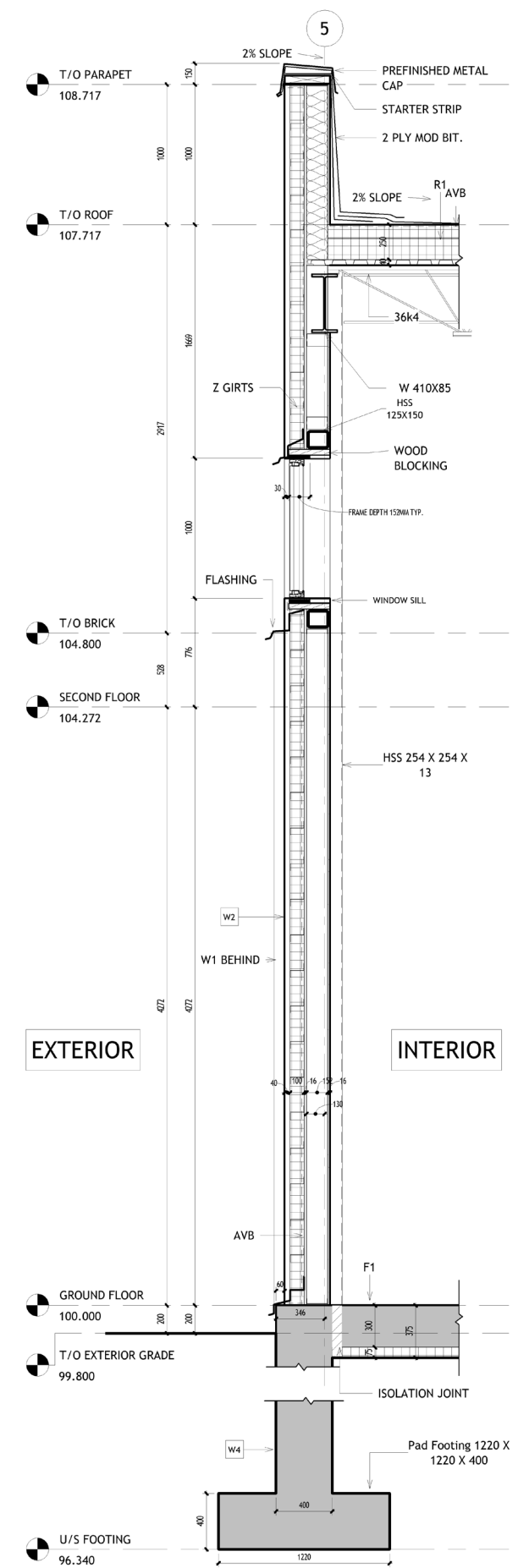
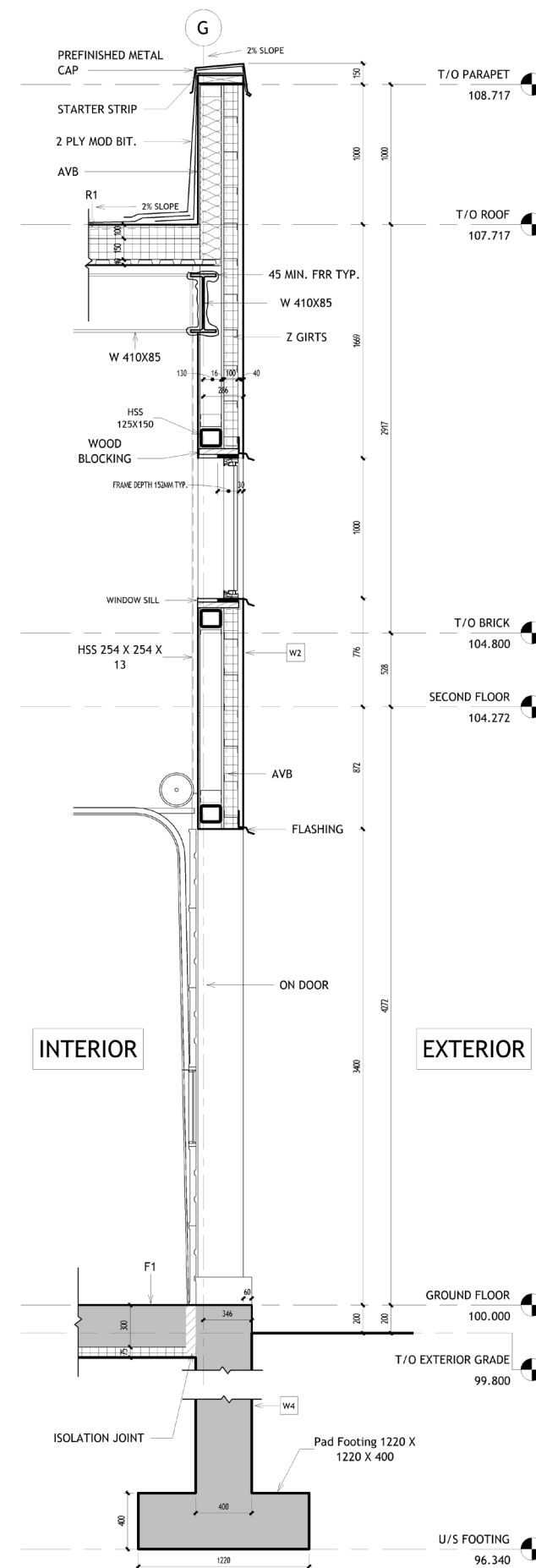
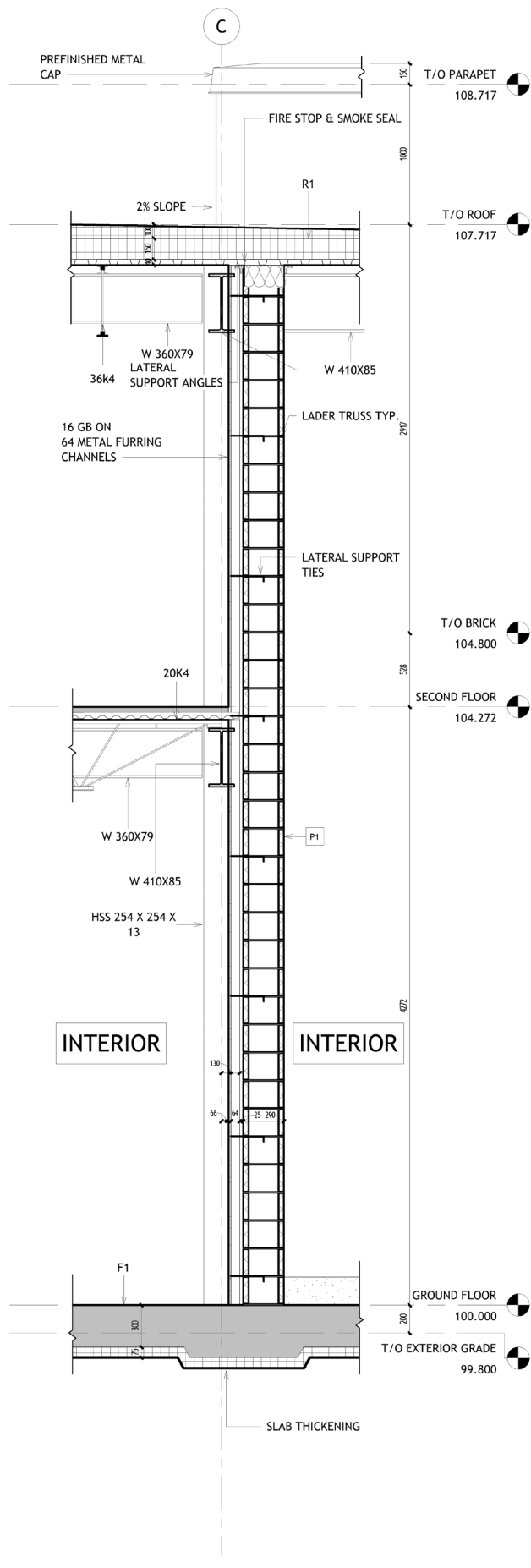
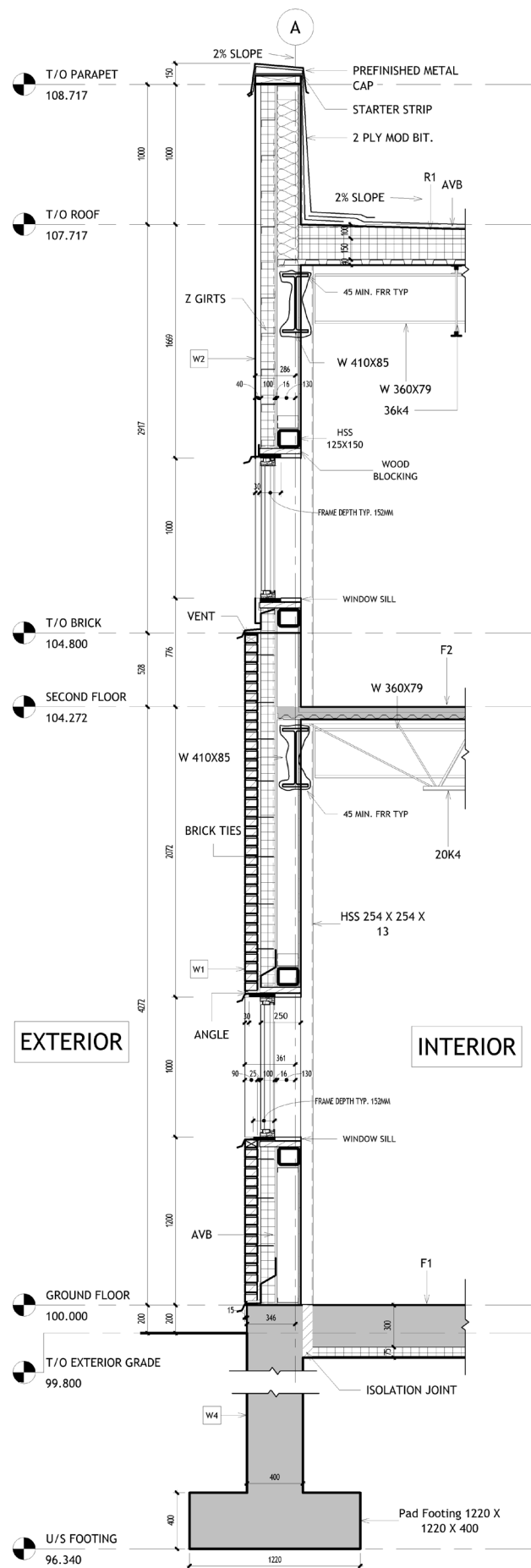

Wall Sections

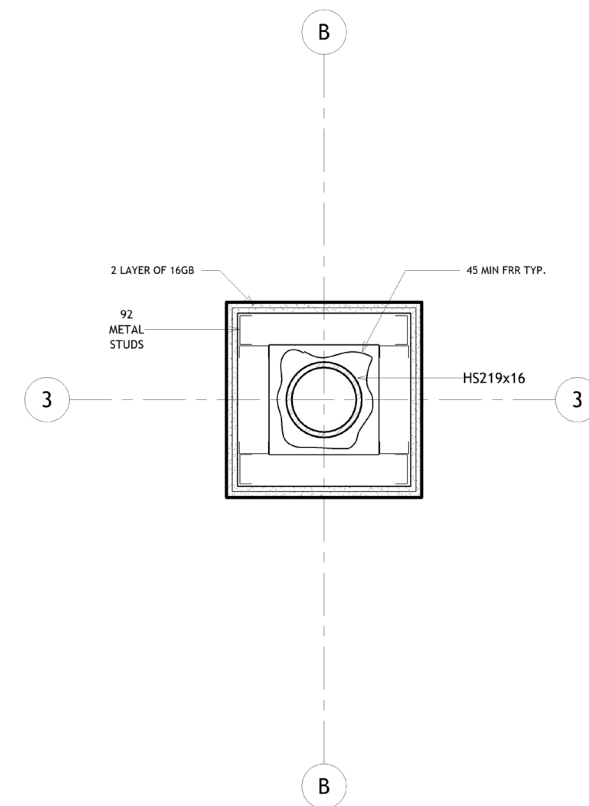
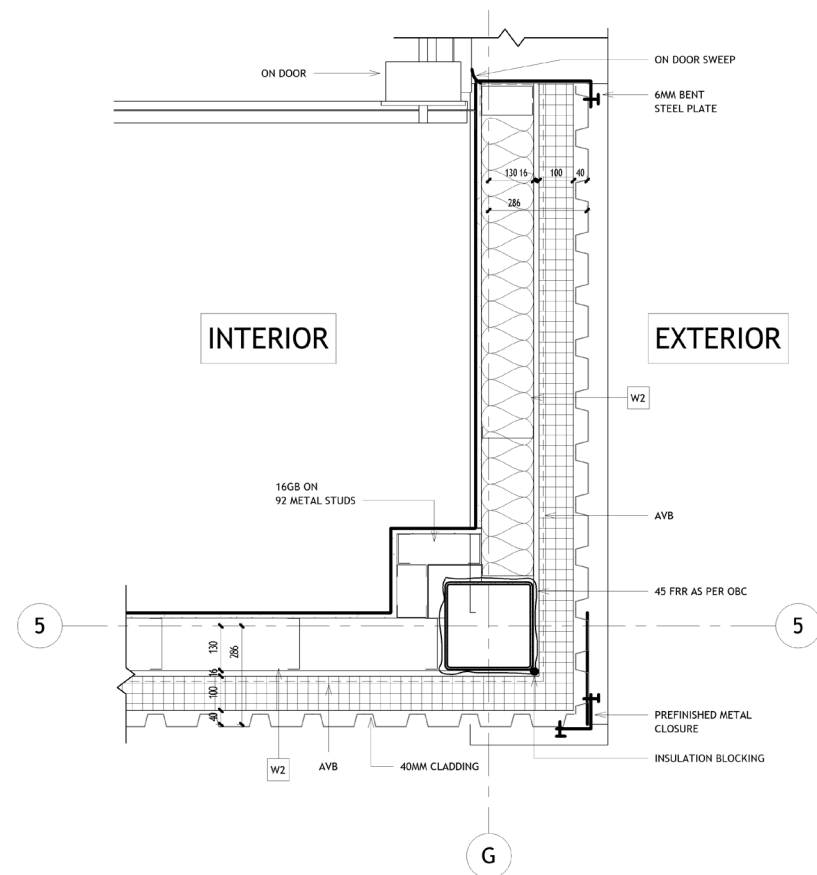
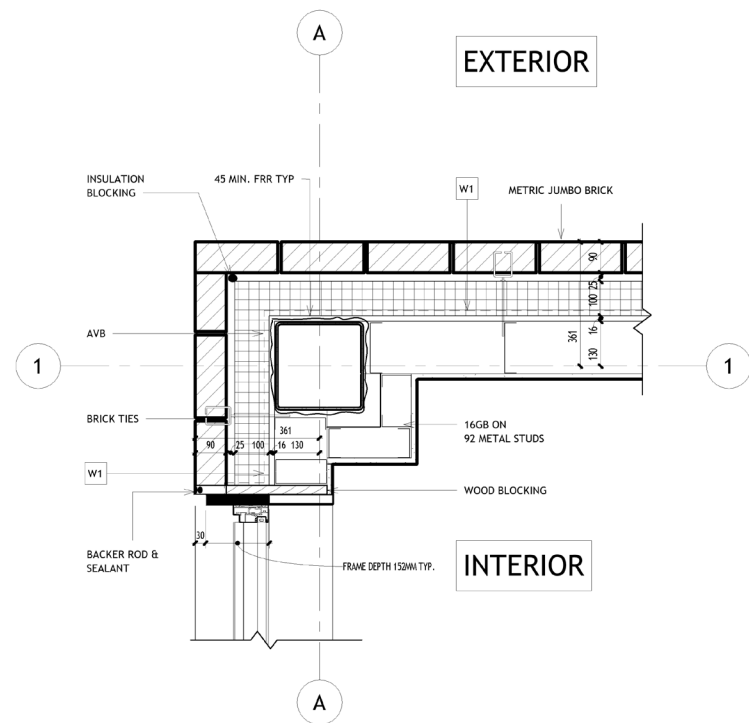
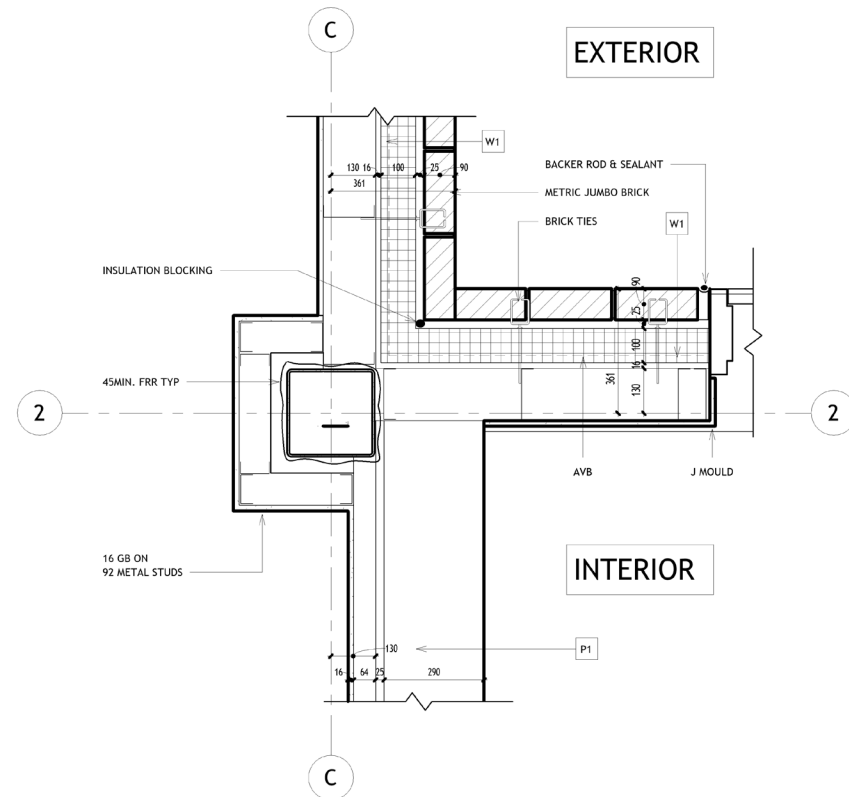
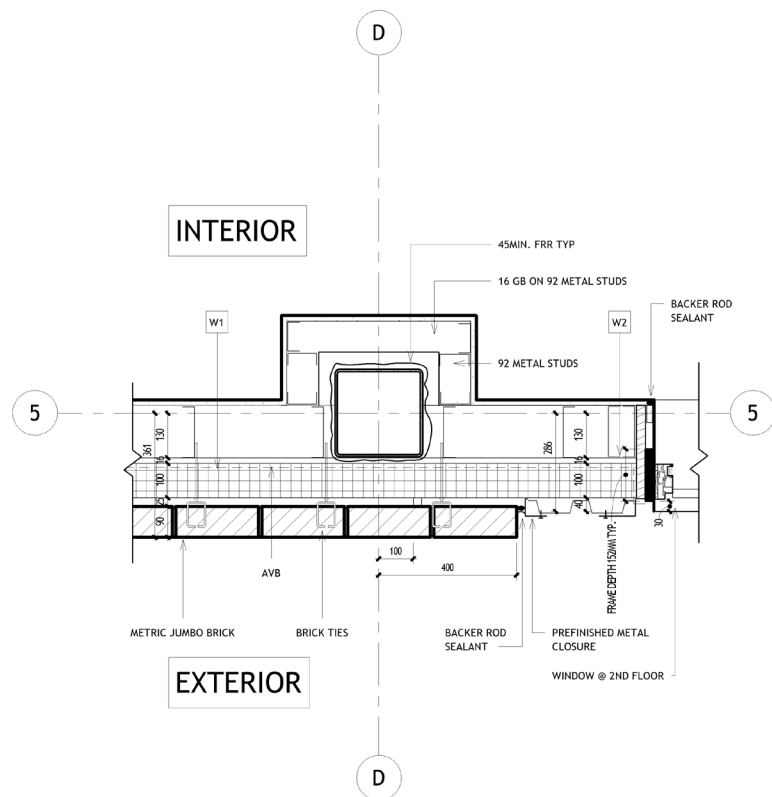
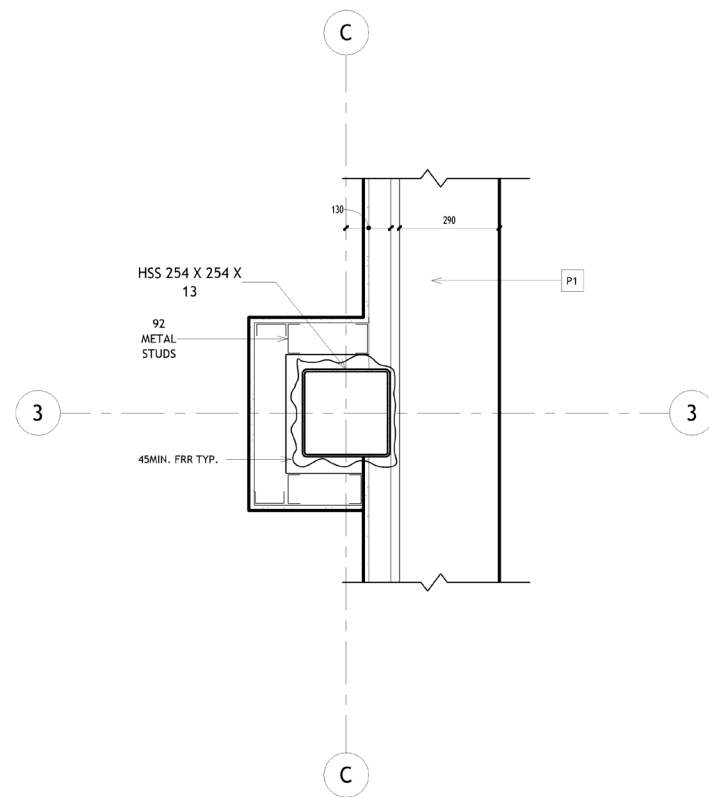

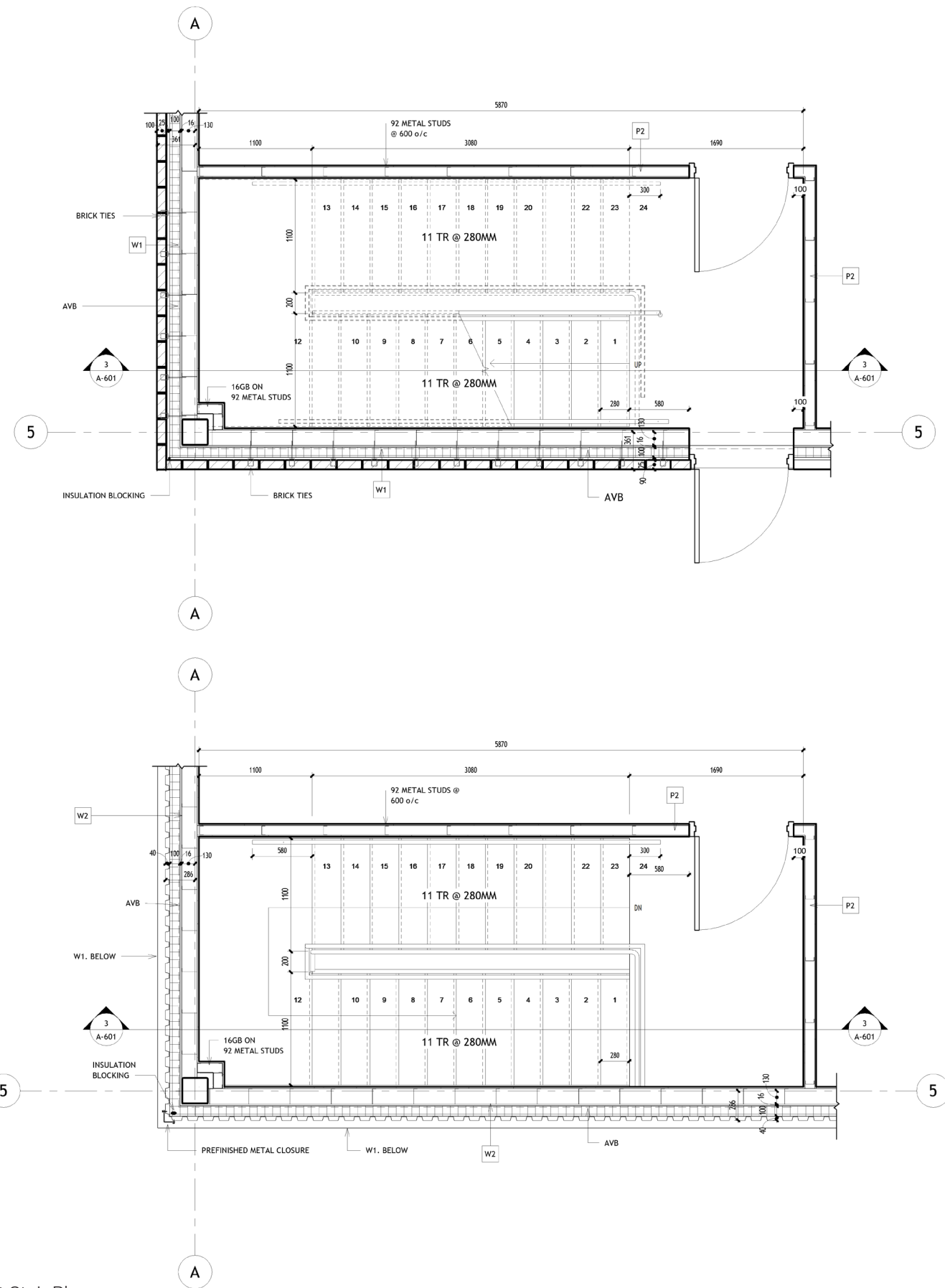

Exit Stair Plans

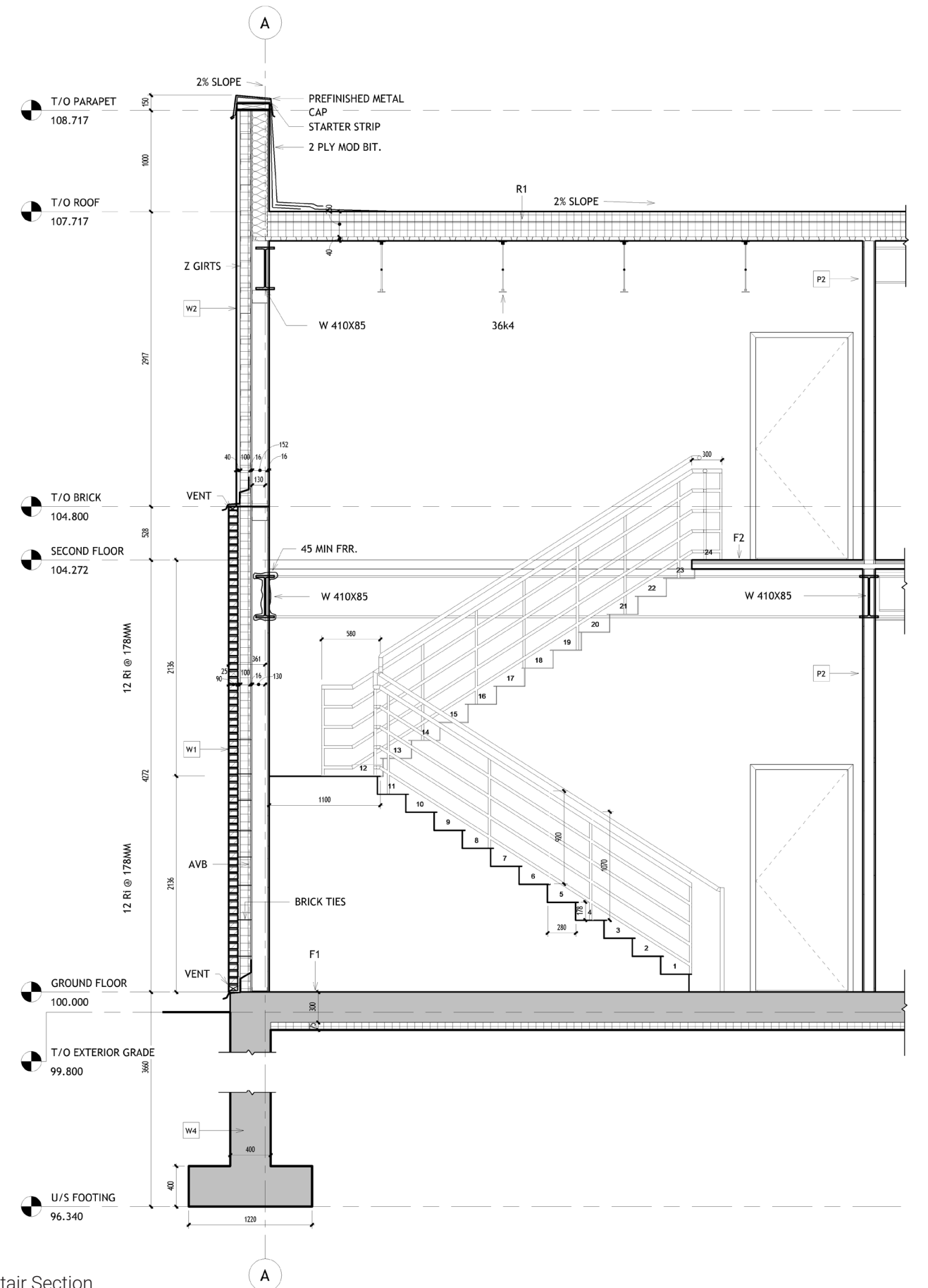

Stair Section

07 Lowertown Medical Center

Year : 2024
Type : Algonquin College Educational Project
Team : Bhargavkumar Mistry, Ekta Chawda
Role : Ontario Building Code, Architecture Design
Status: Completed

For the Lowertown Medical Center, I designed a small medical clinic with a primary focus on compliance with the Ontario Building Code (OBC). My role involved conducting a comprehensive OBC review and ensuring that the architectural design adhered to all relevant regulations, from accessibility to structural and fire safety standards. Utilizing Revit as the core design tool, I explored various design options and iterated on the clinic's layout to optimize both functionality and code compliance. Throughout the process, I made continuous adjustments to the design to meet the specific requirements of the OBC while balancing practical considerations like space planning and patient flow.

To bring the design to life, I used D5 Render to create detailed visualizations, including multiple rendered images and diagrams. These high-quality renderings not only helped convey the clinic's design concept but also provided a clear representation of spatial relationships and architectural features.

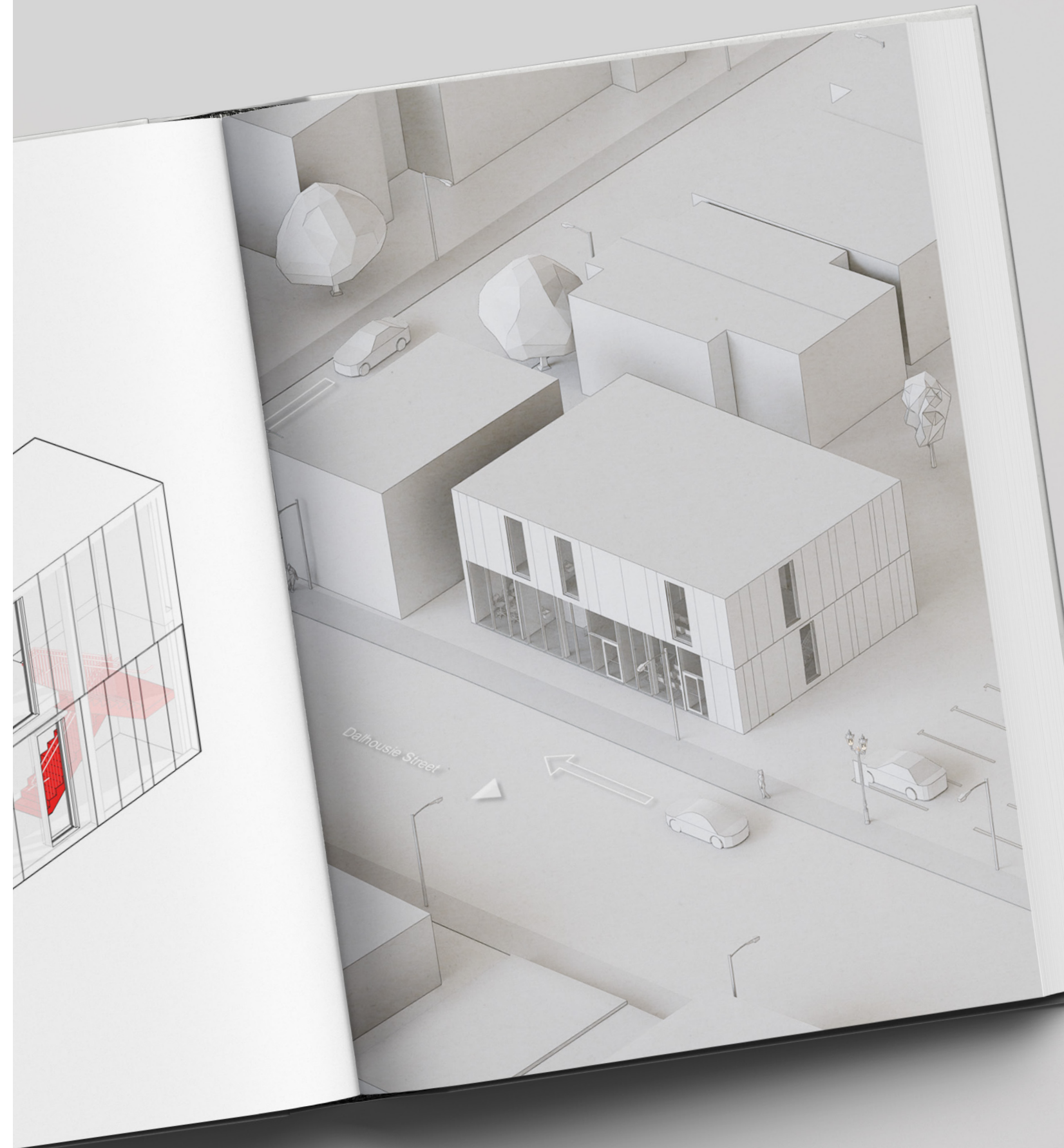

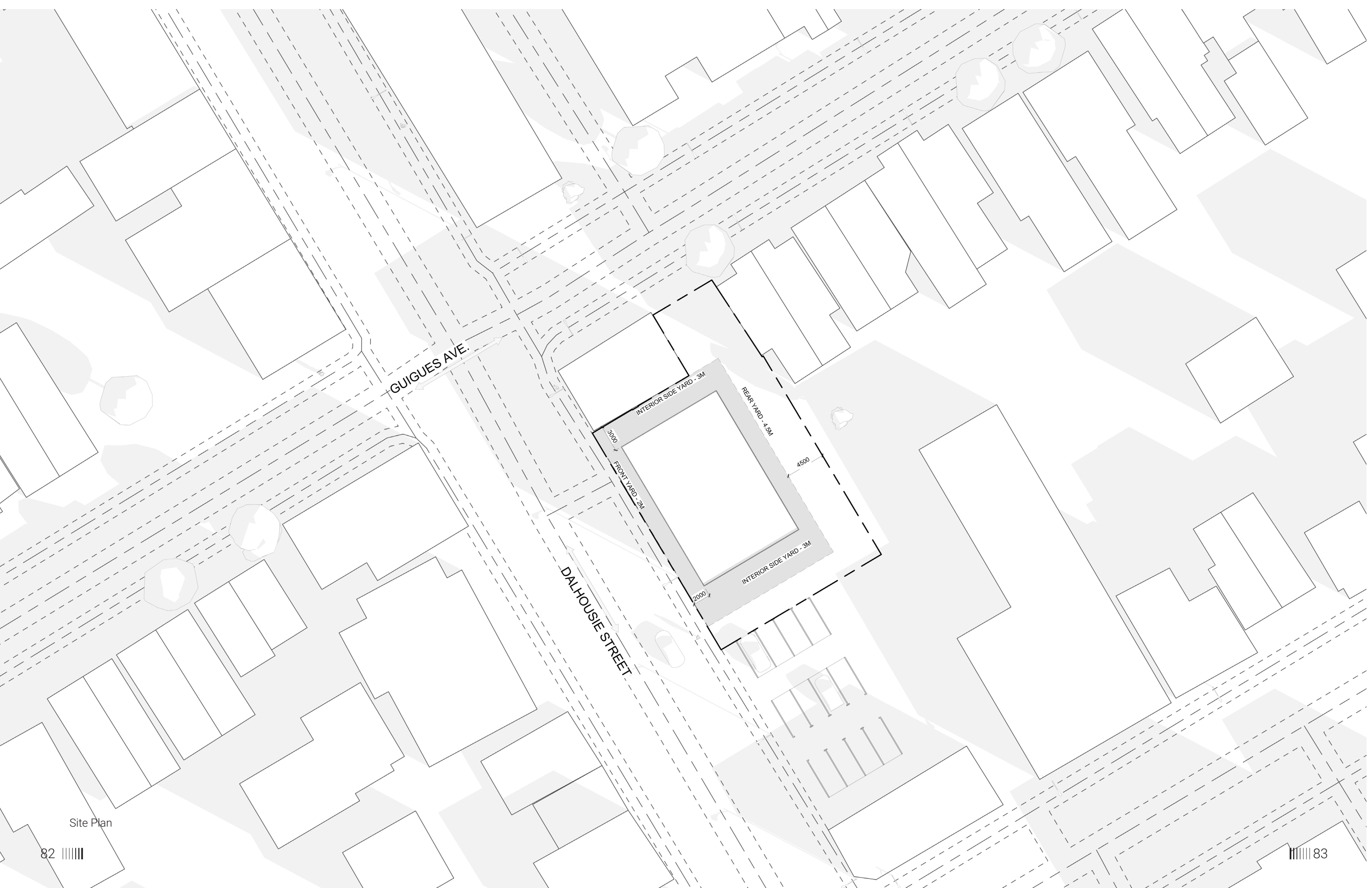

GUGUES AVE.

DALHOUSIE STREET

FRONT YARD - 2M

REAR YARD - 4.5M

INTERIOR SIDE YARD - 3M

2000

4500

2000

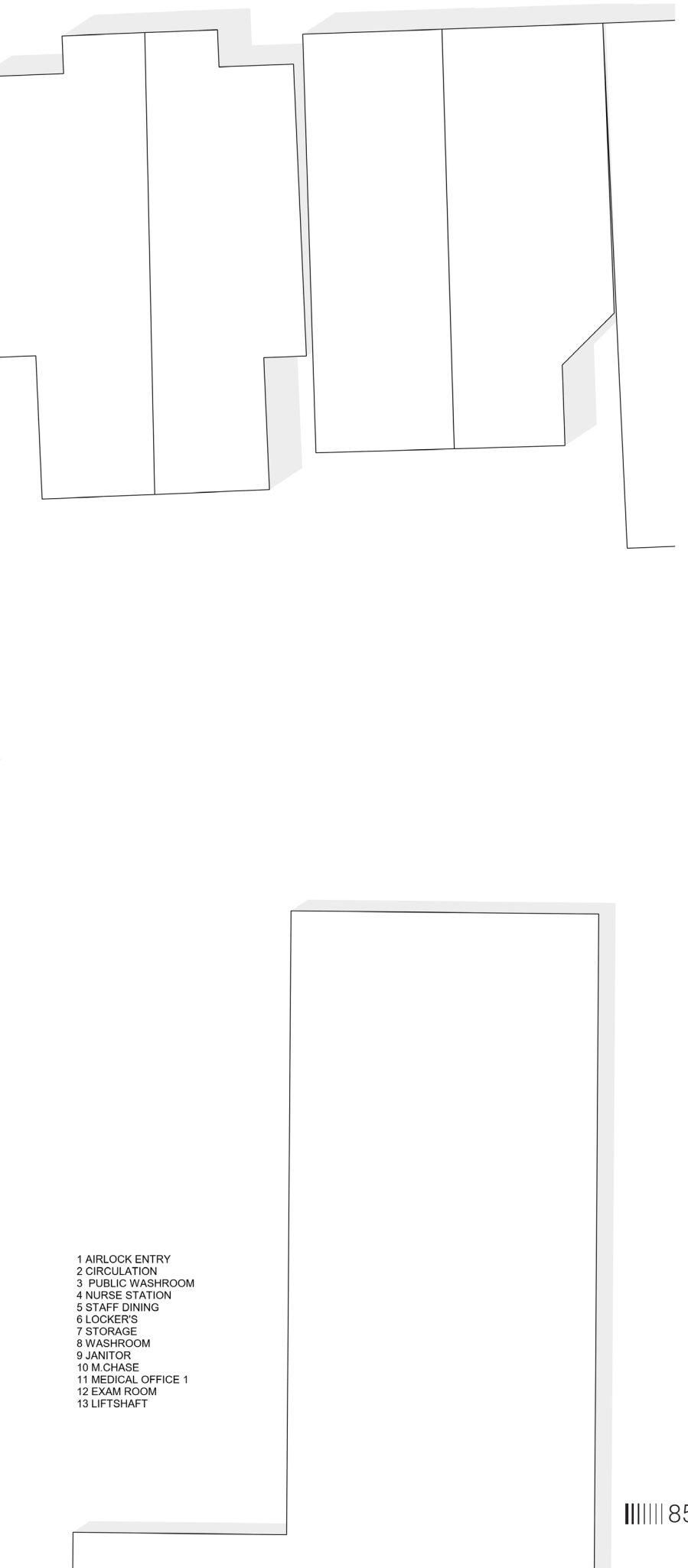
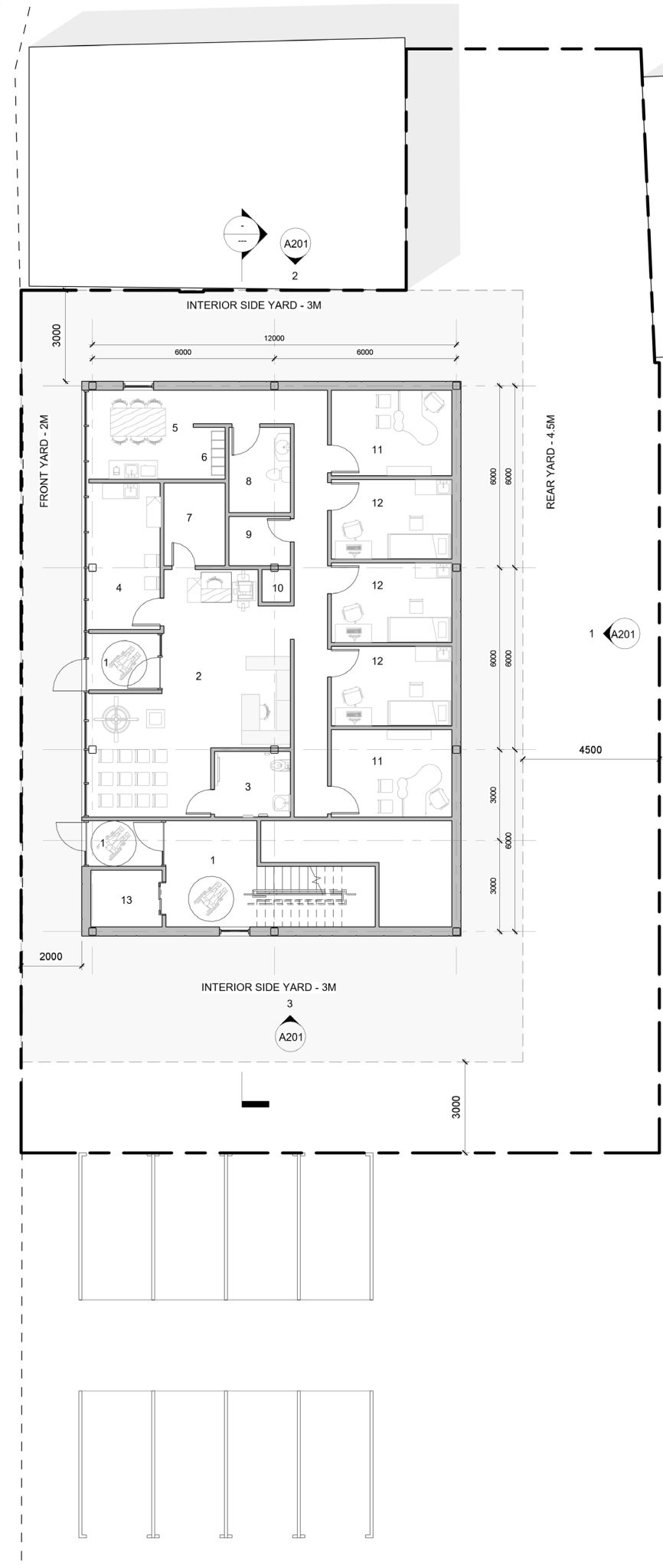
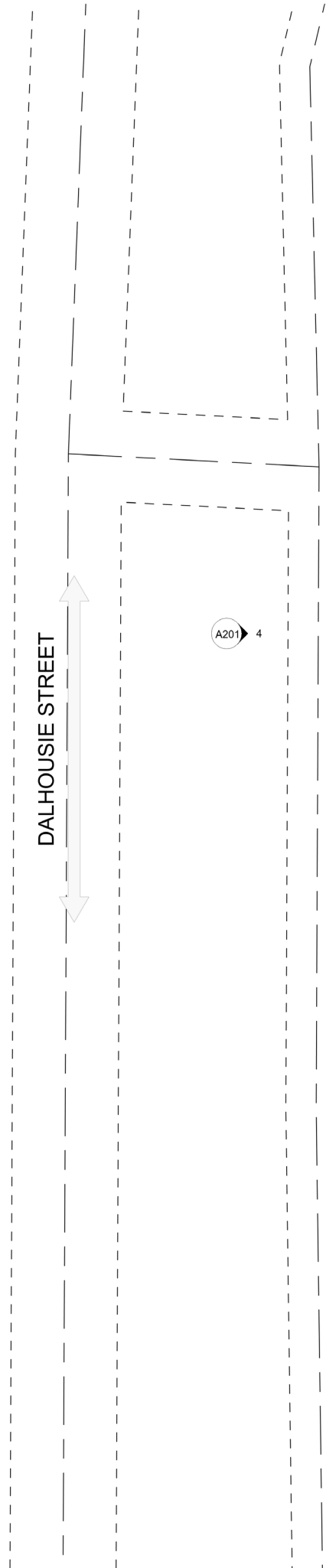
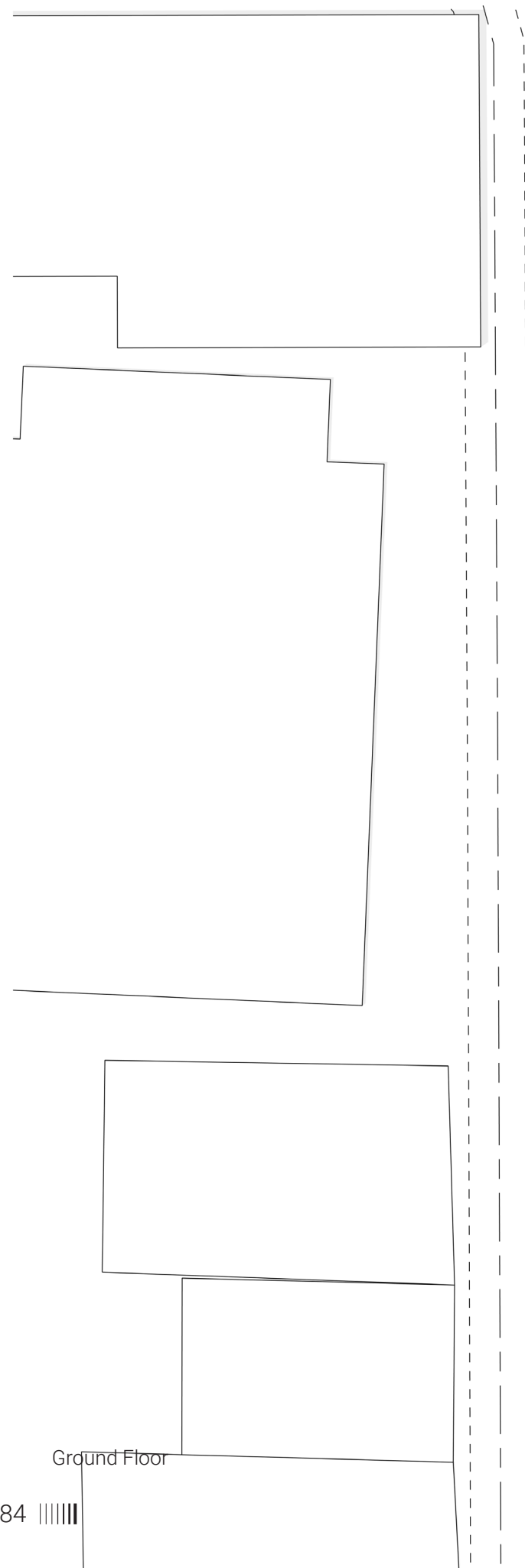

- 1 AIRLOCK ENTRY
- 2 CIRCULATION
- 3 PUBLIC WASHROOM
- 4 NURSE STATION
- 5 STAFF DINING
- 6 LOCKER'S
- 7 STORAGE
- 8 WASHROOM
- 9 JANITOR
- 10 M.CHASE
- 11 MEDICAL OFFICE 1
- 12 EXAM ROOM
- 13 LIFTSHAFT

Ground Floor

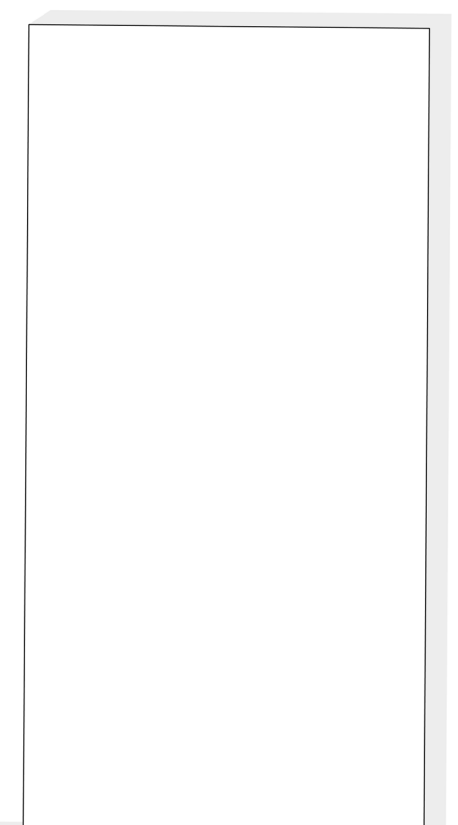
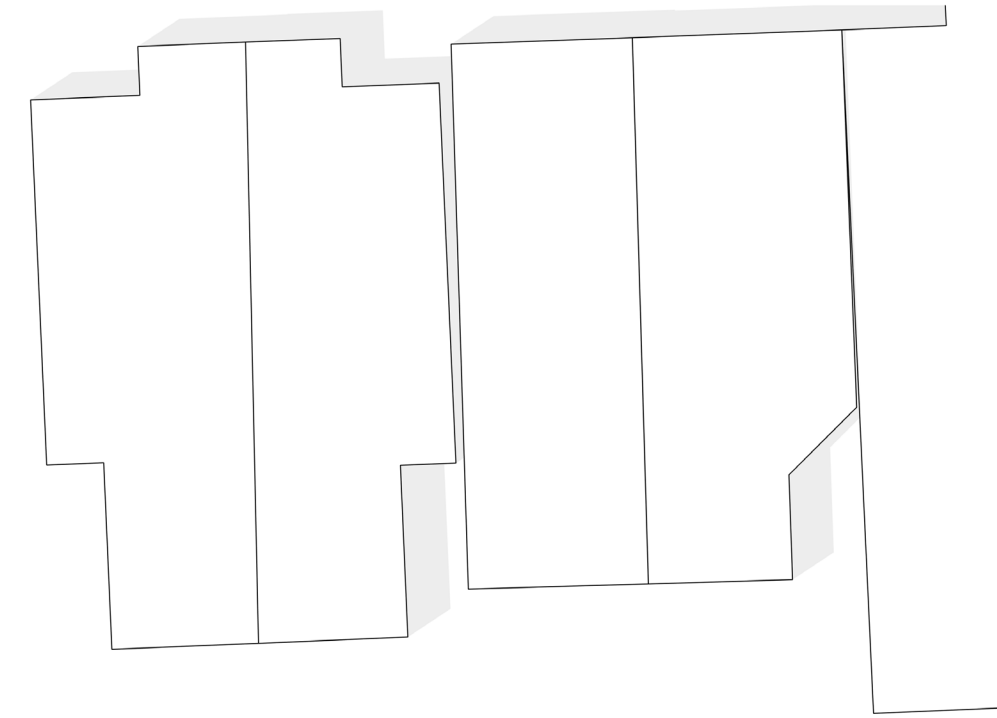
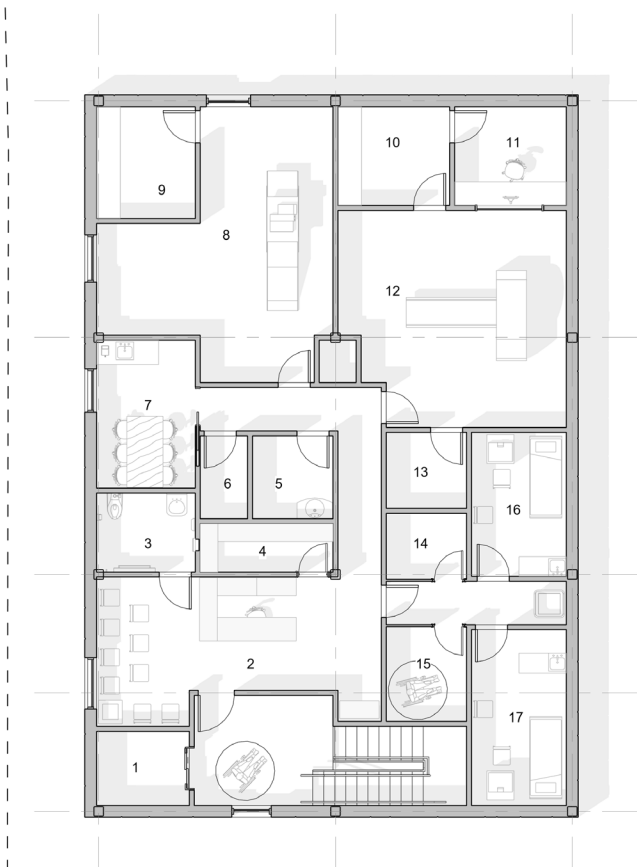
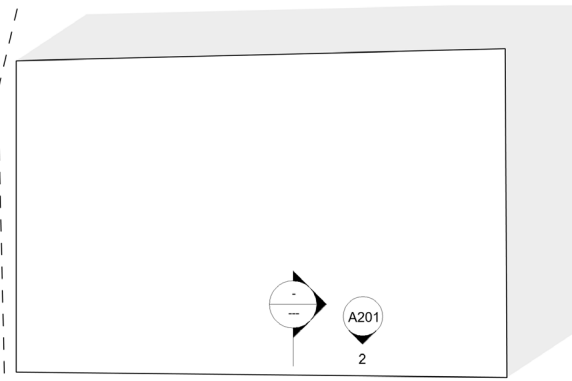
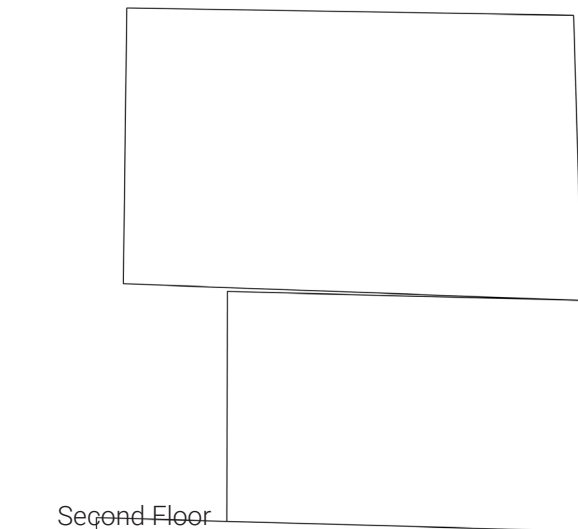
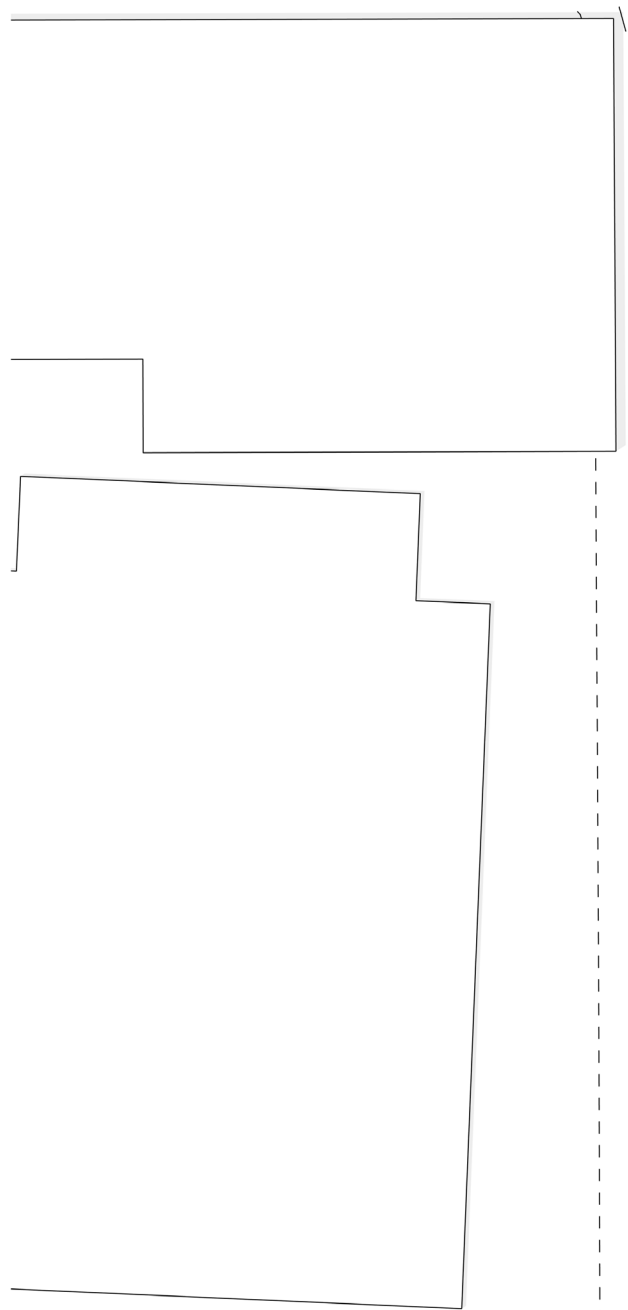

A201 4

A201 1

A201 3

- 1 ELEVATOR
- 2 CIRCULATION
- 3 UNL. WASHROOM
- 4 STORAGE
- 5 WASHROOM
- 6 JANITOR
- 7 STAFF ROOM
- 8 X-RAY ROOM
- 9 DARK ROOM
- 10 EQUIPMENT ROOM
- 11 OBSERVATION ROOM
- 12 CT SCAN ROOM
- 13 PATIENT PREP.
- 14 CHANGING 1
- 15 CHANGING 2
- 16 ULTRASOUND 1
- 17 ULTRASOUND 2

Second Floor

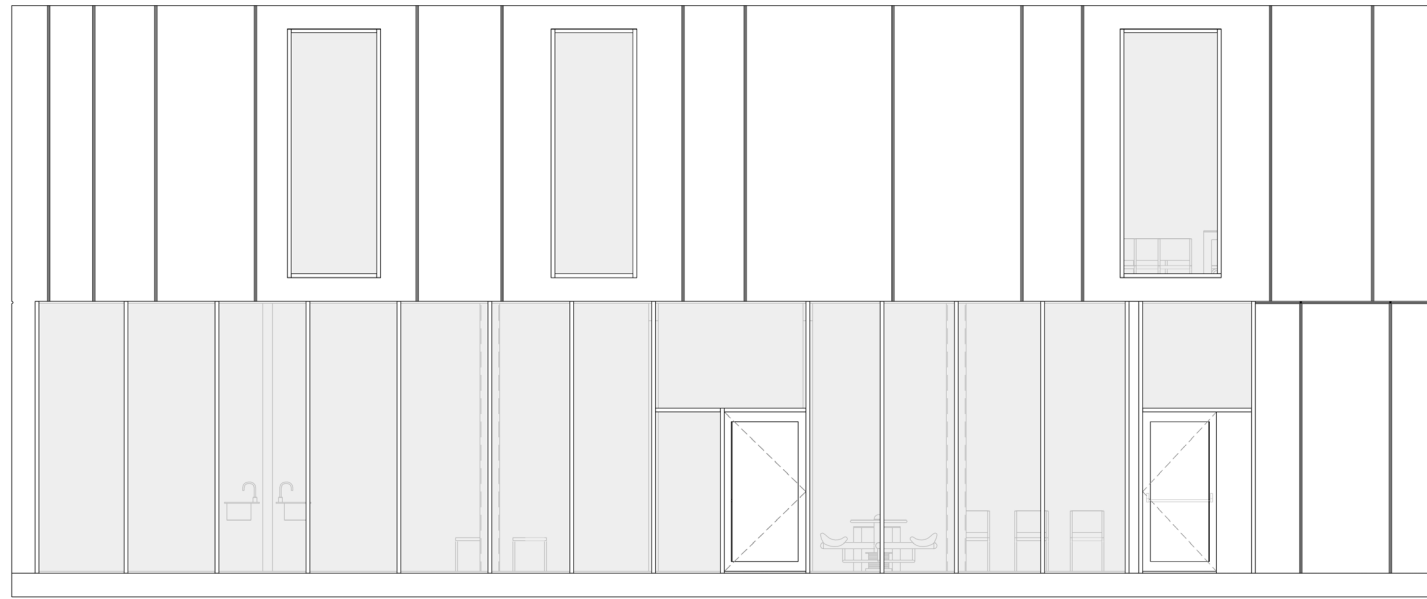

West Elevation

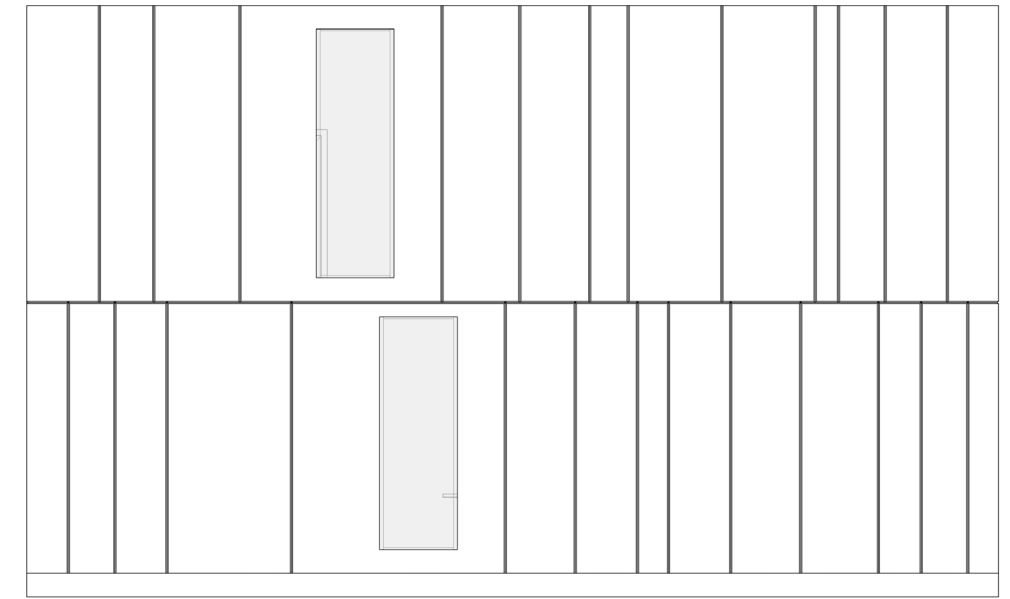

South Elevation

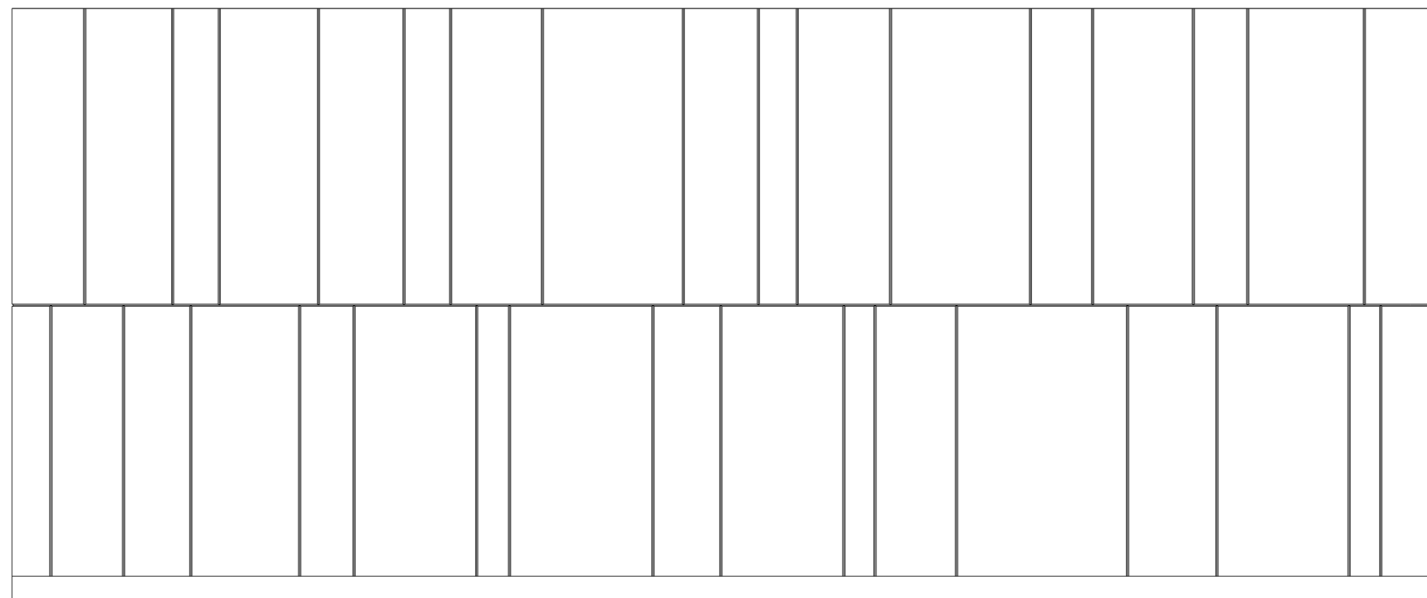

East Elevation

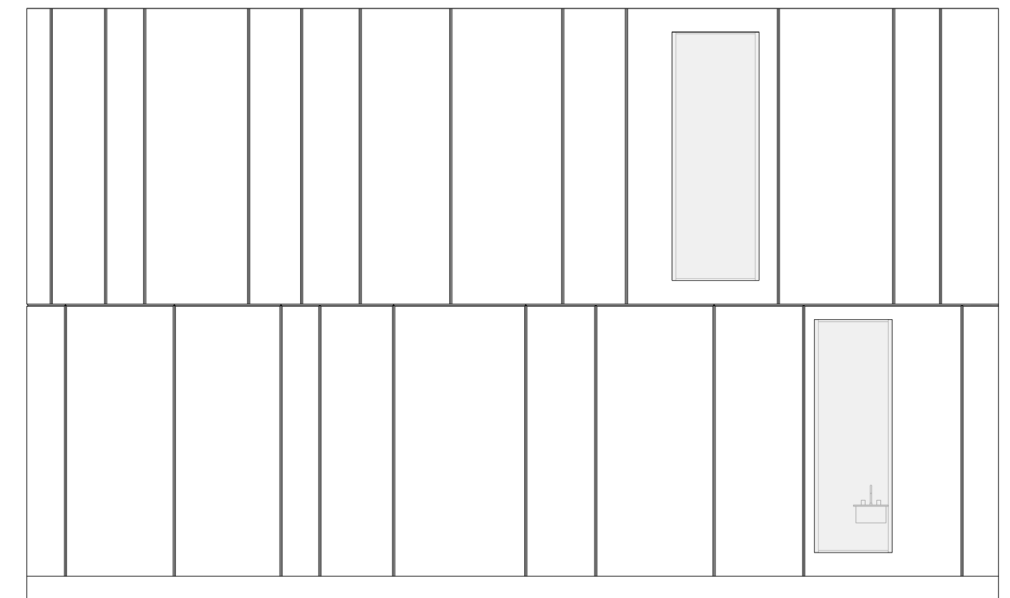

North Elevation

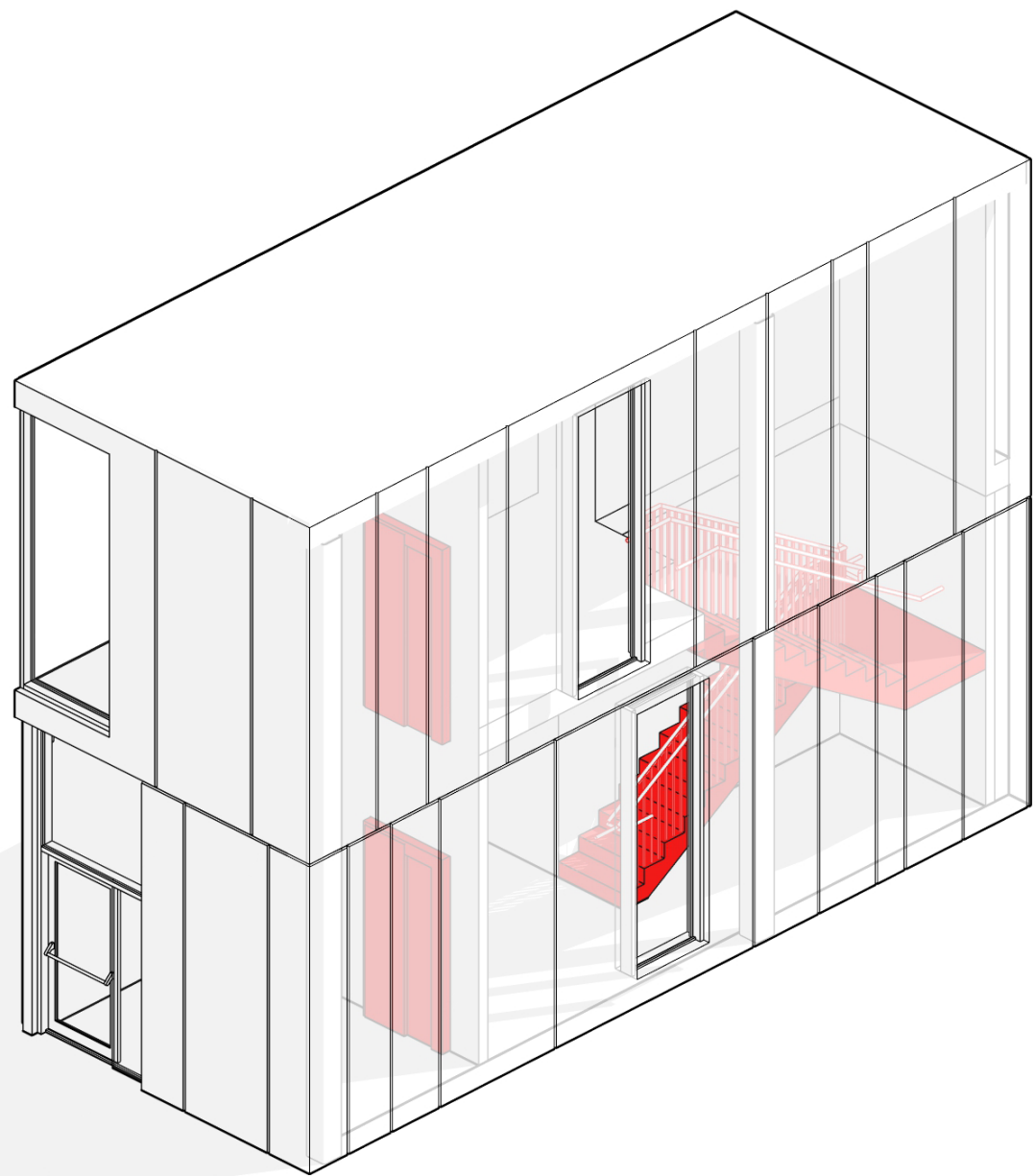

Entrance & Circulation Path

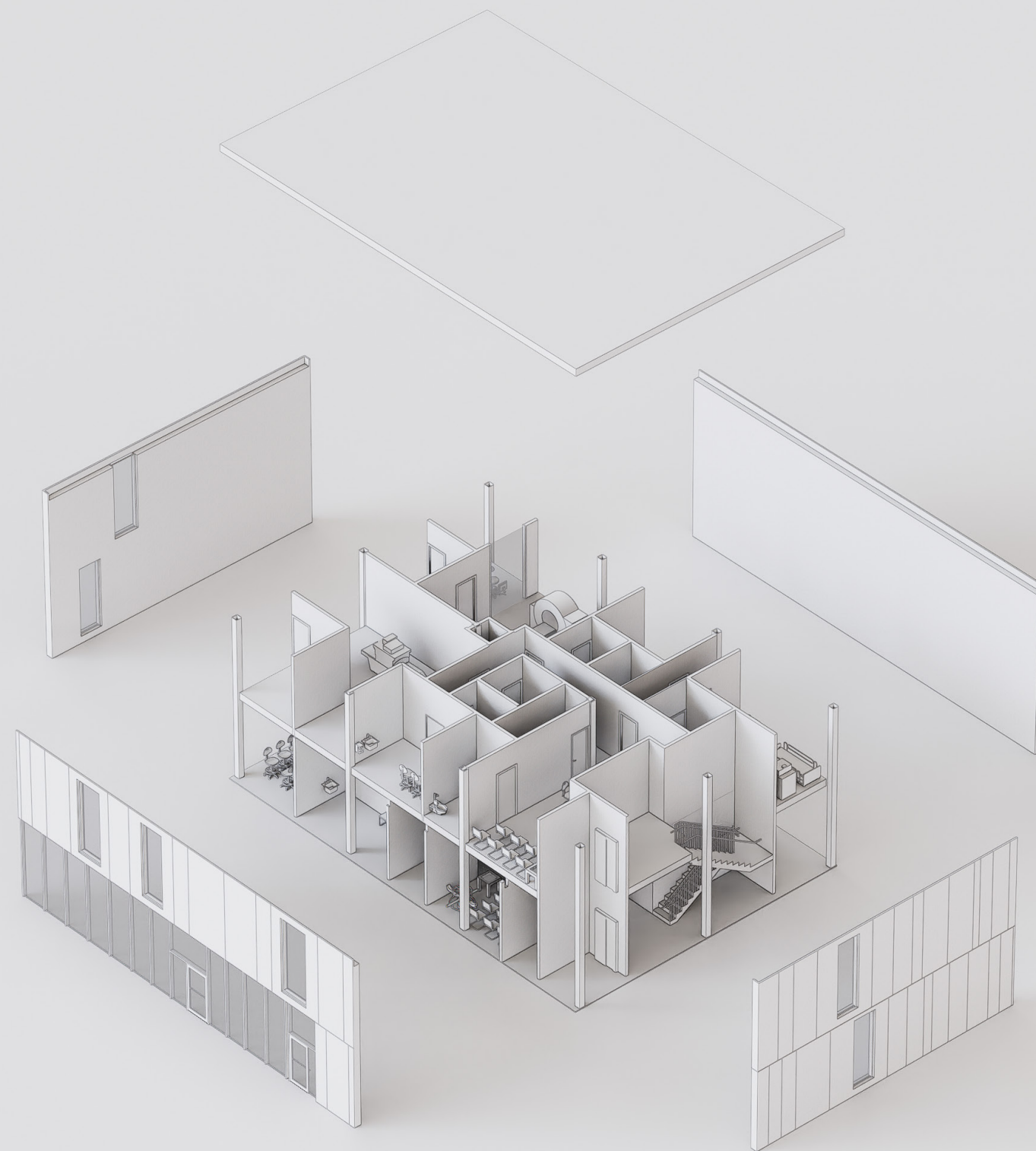

Exploded Axonometric Diagram

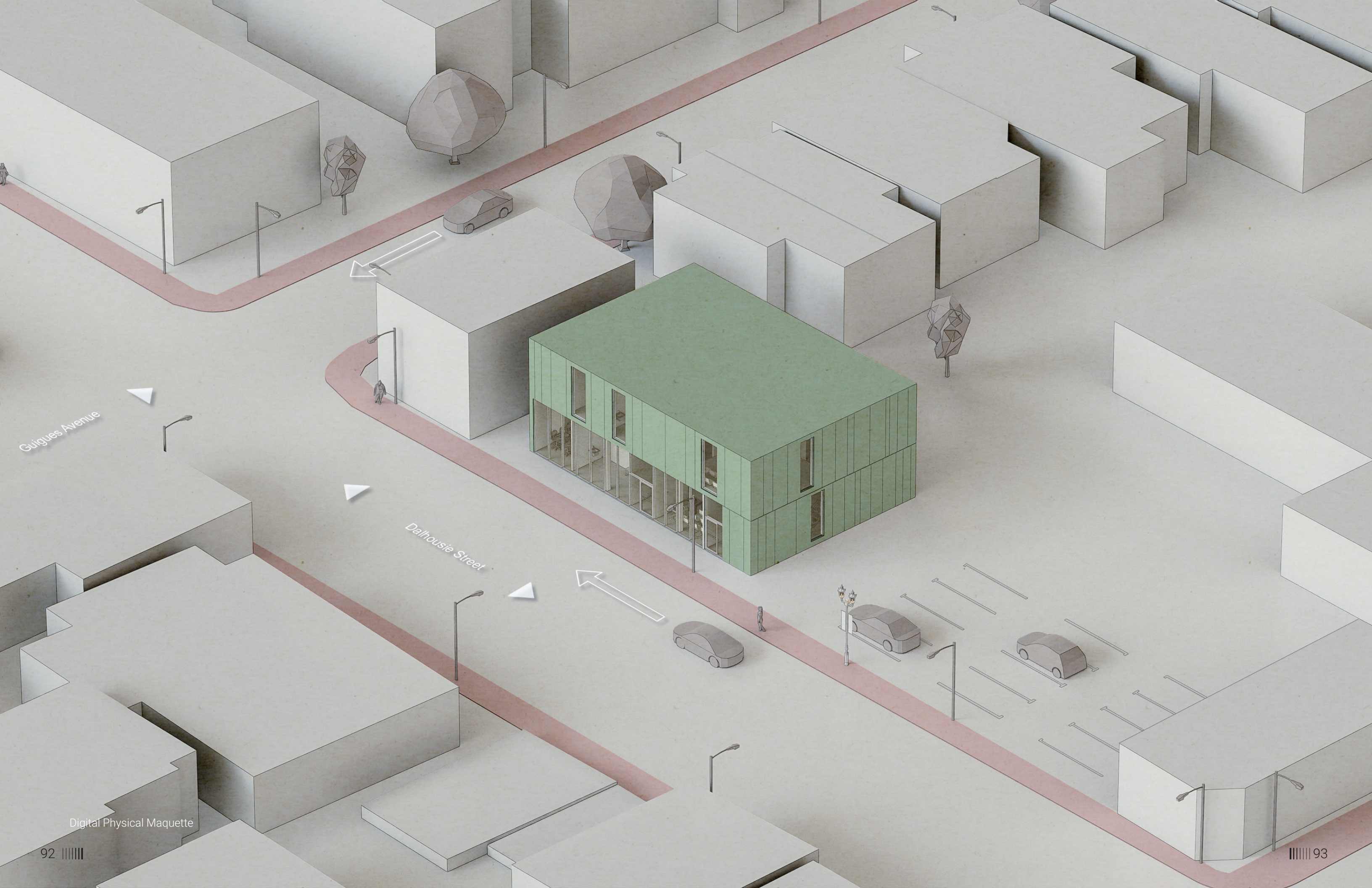

Guigues Avenue

Dalhousie Street



Exterior Night



Exterior Daylight

Contact

mistrybhargav786@gmail.com